



ATTENTION!

If any components of this unit are broken, do not operate properly, or for product returns, please contact Weston Products LLC
Phone: 1-800-814-4895 (Outside the U.S. 440-638-3131)
20365 Progress Drive, Strongsville, Ohio 44149
WestonProducts.com

All Trademarks and Registered Trademarks are property of the respective companies.

SAVE THESE INSTRUCTIONS!

Refer to them often and use them to instruct others.

Roma™
by **WESTON®**

Deluxe Electric
TOMATO STRAINER

MODEL NO. 82-0202-W



Due to constant factory improvements, the product pictured might differ slightly from the product received.

REV03/5/11

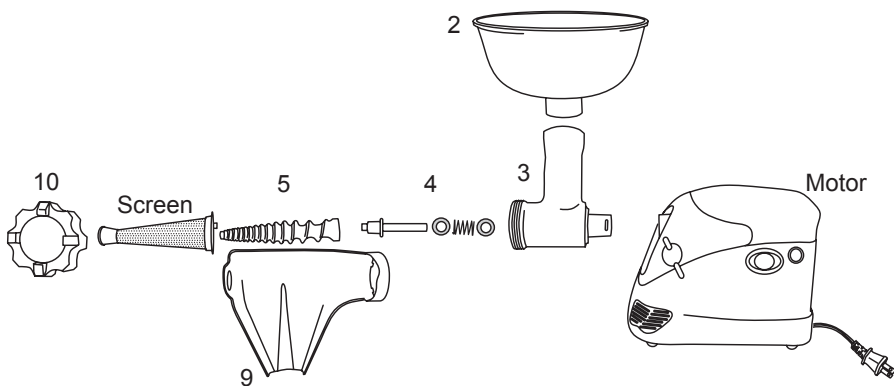
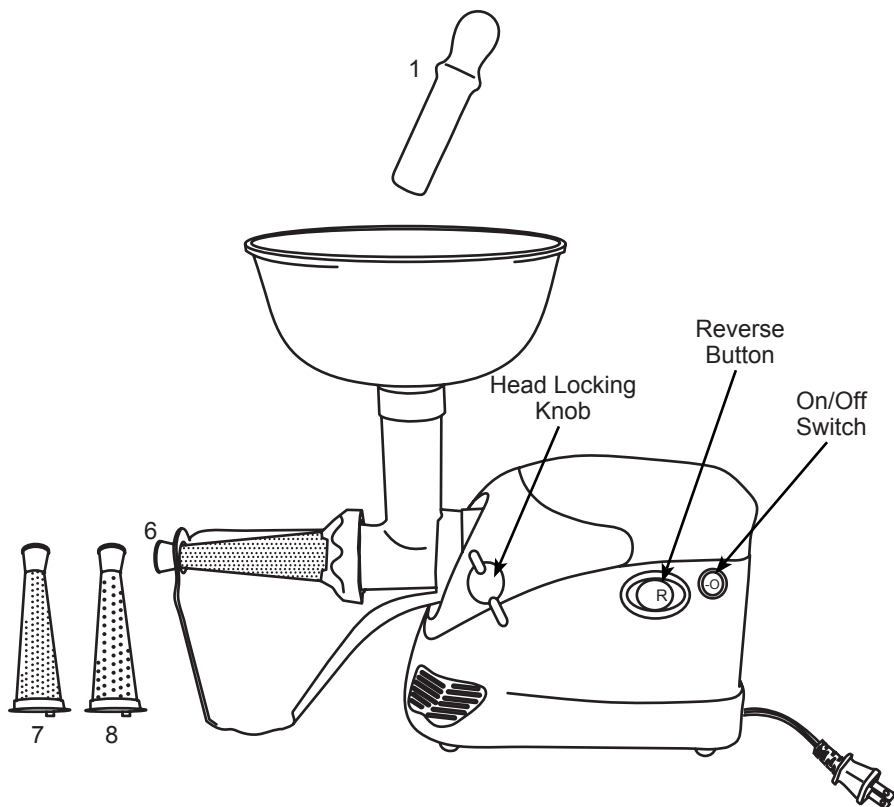

WESTON WARRANTY INFORMATION

SAVE THIS WARRANTY INFORMATION FOR YOUR RECORDS!

Weston Products LLC warrants to the ORIGINAL RETAIL PURCHASER of this product that if operated in accordance with the printed instruction accompanying it, then for a period of 1 year from the date of purchase, the product shall be free from defects in material and workmanship.

The Warranty Card, along with a copy of the original receipt, must be received by Weston Products LLC within 30 days from purchase date for the warranty to apply. Failure to send the completely filled out Warranty Card, along with a copy of the original receipt, will void the warranty.

The product must be delivered to or shipped freight prepaid to Weston Products LLC for warranty services, in either its original packaging or similar packaging affording an equal degree of protection. Damage due to shipping is not the responsibility of the company. Weston Products LLC charges a \$35.00 per hour bench charge. **NOTE:** No repairs will be started without the authorization of the customer. The return shipping cost to the customer will be added to the repair invoice.

Weston Products LLC will repair (or at its discretion, replace) the product free of charge, if in the judgment of the company, it has been proven to be defective as to seller's labor and material, within the warranty period.

New or rebuilt replacements for factory defective parts will be supplied for one (1) year from the date of purchase. Replacement parts are warranted for the remainder of the original warranty period.

For non-warranty repairs, contact Weston Products LLC's Customer Service at 1-800-814-4895 M-F 8am-5pm EST (outside of the United States 440-638-3131) to obtain a Return Merchandise Authorization Number (RMA Number). Weston Products LLC will refuse all returns that do not contain this number. **DO NOT RETURN THE UNIT WITHOUT PROPER AUTHORIZATION FROM WESTON PRODUCTS LLC.**

LIMITATIONS: The warranty is void if the product is used for any purpose other than that for which it is designed. The product must not have been previously altered, repaired, or serviced by anyone else other than Weston Products LLC. If applicable, the serial number must not have been altered or removed. The product must not have been subjected to accident in transit or while in the customer's possession, misused, abused, or operated contrary to the instructions contained in the instruction manual. This includes failure caused by neglect of reasonable and necessary maintenance, improper line voltage and acts of nature. This warranty is not transferable and applies only to U.S. and Canadian sales.

Except to the extent prohibited by applicable law, no other warranties whether expressed or implied, including warranty merchantability and fitness for a particular purpose, shall apply to this product. Under no circumstances shall Weston Products LLC be liable for consequential damages sustained in connection with said product and Weston Products LLC neither assumes nor authorizes any representative or other person to assume for it any obligation or liability other than such as is expressly set forth herein. Any applicable implied warranties are also limited to the one (1) year period of the limited warranty.

This warranty covers only the product and its specific parts, not the food or other products processed in it.

CUT ALONG THE DOTTED LINE AND SEND THE WARRANTY CARD ALONG WITH A COPY OF YOUR ORIGINAL PURCHASE RECEIPT TO:

Weston Products LLC
20365 Progress Drive, Strongsville, OH 44149

WESTON WARRANTY CARD

SEND THIS CARD ALONG WITH A COPY OF YOUR ORIGINAL PURCHASE RECEIPT TO:
 WESTON WARRANTY, WESTON PRODUCTS LLC, 20365 PROGRESS DRIVE, STRONGSVILLE, OH 44149

Customer Name: _____
 Address: _____
 City/State/Zip: _____
 Telephone Number: (_____) _____
 E-Mail Address: _____
 Original Date of Purchase: ____/____/____
 Product Model #: _____
 Serial # (if applicable): _____



ADDITIONAL ACCESSORIES

ACCESSORY DESCRIPTION	PART NUMBER
Food Grade Silicone Spray	03-0101-W
Electric Pasta Machine	01-0601-W
Traditional Pasta Machine	01-0201
5-Piece Canning Kit	83-2017-W
Pro 2300 Vacuum Sealer	65-0201

These products and many more products can be ordered by visiting **WestonProducts.com** or by calling Weston Products LLC Toll Free at 1-800-814-4895 Monday thru Friday 8:00am-5:00pm EST. Outside the U.S. call 440-638-3131

COMPONENT LIST

DIAGRAM NUMBER	PART DESCRIPTION	PART NUMBER
1	Stomper	82-0109
2	Hopper	82-0210
3	Head	82-0111
Drive Shaft Assembly	Spring	
	Metal Washer (2)	82-0124
	Drive Shaft	
5	Plastic Auger	82-0125
6	Standard Tomato/Berry Screen	82-0129
7	Pumpkin Screen	82-0211
8	Salsa Screen	82-0212
9	Chute	82-0130
10	Front Ring Nut	82-0118

If any components of this unit are broken or the unit does not operate properly, call Weston Products LLC Toll Free at

1-800-814-4895

Monday thru Friday 8:00am-5:00pm EST. Outside the U.S. call 440-638-3131

CAUTION! It is important to follow the "Food Safety" guidelines outlined in this manual. For the most up to date instruction visit the USDA website.

WARNING!

KEEP FINGERS, HANDS, OTHER BODY PARTS AND OBJECTS CLEAR OF THE HEAD!

ALWAYS USE THE PROVIDED STOMPER TO PUSH FOOD INTO THE HOPPER/HEAD!

NEVER OPERATE THIS APPLIANCE WITHOUT THE HOPPER INSTALLED ONTO THE HEAD!

KEEP CHILDREN AWAY!
ALWAYS DISCONNECT FROM THE POWER SOURCE WHEN NOT IN USE!



DANGER! 120-Volts
TO PREVENT ELECTRIC SHOCK
DO NOT OPEN OR REMOVE THE BACK PANEL!

NEVER IMMERSE APPLIANCE BODY IN WATER!
NEVER USE ELECTRICAL APPLIANCES NEAR WATER!
NEVER LEAVE THIS APPLIANCE UNATTENDED!
Disconnect from power supply when not in use!

Before cleaning, assembling or disassembling, make sure the **APPLIANCE IS OFF** and the **PLUG IS REMOVED FROM THE OUTLET/POWER SOURCE!**



WARNING!

KEEP FINGERS, HANDS, OTHER BODY PARTS AND OBJECTS CLEAR OF THE HEAD!

ALWAYS USE THE PROVIDED STOMPER TO PUSH FOOD INTO THE HOPPER/HEAD!

NEVER OPERATE THIS APPLIANCE WITHOUT THE HOPPER INSTALLED ONTO THE HEAD!

KEEP CHILDREN AWAY!
ALWAYS DISCONNECT FROM THE POWER SOURCE WHEN NOT IN USE!



DANGER! 120-Volts
TO PREVENT ELECTRIC SHOCK
DO NOT OPEN OR REMOVE THE BACK PANEL!

NEVER IMMERSE APPLIANCE BODY IN WATER!
NEVER USE ELECTRICAL APPLIANCES NEAR WATER!
NEVER LEAVE THIS APPLIANCE UNATTENDED!
Disconnect from power supply when not in use!

Before cleaning, assembling or disassembling, make sure the **APPLIANCE IS OFF** and the **PLUG IS REMOVED FROM THE OUTLET/POWER SOURCE!**



GENERAL SAFETY RULES



WARNING!

READ AND FULLY UNDERSTAND ALL INSTRUCTIONS AND WARNINGS PRIOR TO USING THIS PRODUCT. YOUR SAFETY IS MOST IMPORTANT! FAILURE TO COMPLY WITH PROCEDURES AND SAFE GUARDS MAY RESULT IN SERIOUS INJURY OR PROPERTY DAMAGE. REMEMBER: YOUR PERSONAL SAFETY IS YOUR RESPONSIBILITY!

1. Thoroughly inspect the **Tomato Strainer** before each use. DO NOT use the **Tomato Strainer** if any part (including the **Power Cord** and **Plug**) is broken or damaged. If the **Tomato Strainer** is damaged in any way, contact Customer Service at the telephone number listed on the back of this booklet.
2. BEFORE using the **Tomato Strainer** for the first time, thoroughly wash all parts that will contact food in warm soapy water. Rinse with clean water. Dry all parts before assembling the **Tomato Strainer**. Only the plastic parts of the **Tomato Strainer** are top rack dishwasher safe. DO not place metal parts or the **Motor** of the **Tomato Strainer** in the dishwasher.
3. NEVER immerse the **Motor** in water or other liquid. Clean it by wiping with a damp cloth.
4. ONLY plug the **Tomato Strainer** into a 120 Volt, 60 Hz outlet. AVOID using extension cords.
5. ALWAYS DISCONNECT the **Tomato Strainer** from the power source when not in use.
6. Before cleaning, assembling or disassembling the **Tomato Strainer**, make sure it is turned off "O" and disconnected from the power source. Test to make sure there is no power to the **Motor** by switching the **Motor** on "-" and off "O".
7. KEEP FINGERS AND OTHER FOREIGN OBJECTS AWAY from the **Tomato Strainer** inlet during operation.
8. ONLY use the **Stomper** to push items into the **Tomato Strainer**. DO NOT use your fingers!
9. KEEP CHILDREN AWAY FROM THE **TOMATO STRAINER**. DO NOT LEAVE THE **TOMATO STRAINER** UNATTENDED.
10. To prevent unintentional starting, make sure the power switch is in the off "O" position before connecting the **Tomato Strainer** to the power source.
11. DO NOT grind bones, nuts or other hard items into the **Tomato Strainer**.
12. DO NOT use accessories from other manufacturers. Use of unauthorized accessories will void the warranty.
13. Tie back loose hair and clothing, roll up long sleeves, and remove ties and jewelry including watches, rings and bracelets before operating the **Tomato Strainer**.
14. If the **Tomato Strainer** becomes jammed, briefly engage in reverse to clear blockage.
15. DO NOT use the **Tomato Strainer** while under the influence of drugs or alcohol.
16. For indoor use only.
17. Household use only.

hamper. The hamper won't chill food - it just keeps food cold when properly packed with ice. Hot cooked foods should be placed in shallow containers and immediately refrigerated so they cool rapidly. Make sure to cover foods after they are cool.

NOTE: Special considerations must be made when using venison or other wild game, since it can become heavily contaminated during field dressing. Venison is often held at temperatures that could potentially allow bacteria to grow, such as when it is being transported. Refer to the USDA Meat and Poultry Department for further questions or information on meat and food safety.

SAVE THESE INSTRUCTIONS!

Refer to them often and use them to instruct others.

WARNING!

KEEP FINGERS, HANDS, OTHER BODY PARTS AND OBJECTS CLEAR OF THE HEAD!

ALWAYS USE THE PROVIDED STOMPER TO PUSH FOOD INTO THE HOPPER/HEAD!

NEVER OPERATE THIS APPLIANCE WITHOUT THE HOPPER INSTALLED ONTO THE HEAD!

KEEP CHILDREN AWAY!
ALWAYS DISCONNECT FROM THE POWER SOURCE WHEN NOT IN USE!



DANGER! 120-Volts

TO PREVENT ELECTRIC SHOCK
DO NOT OPEN OR REMOVE THE BACK PANEL!



**NEVER IMMERSE APPLIANCE BODY IN WATER!
NEVER USE ELECTRICAL APPLIANCES NEAR WATER!
NEVER LEAVE THIS APPLIANCE UNATTENDED!**

Disconnect from power supply when not in use!
Before cleaning, assembling or disassembling,
make sure the APPLIANCE IS OFF and the PLUG IS
REMOVED FROM THE OUTLET/POWER SOURCE!

FOOD SAFETY

There are basic rules to follow when handling food. They are **COOK, SEPARATE, CLEAN, and CHILL.**

COOK

It's crucial to cook food to a safe internal temperature to destroy bacteria that is present. The safety of hamburgers and other foods made with ground meat has been receiving a lot of attention lately, and with good reason. When meat is ground, the bacteria present on the surface is mixed throughout the ground mixture. If this ground meat is not cooked to at least 160°F to 165°F (71°C to 74°C), bacteria will not be destroyed and there's a good chance you will get sick.

Solid pieces of meat like steaks and chops don't have dangerous bacteria like E. coli on the inside, so they can be served more rare. Still, any beef cut should be cooked to an internal temperature of at least 145°F (63°C) (medium rare). The safe temperature for poultry is 180°F (82°C) and solid cuts of pork should be cooked to 160°F (71°C). Eggs should be thoroughly cooked too. If you are making a meringue or other recipe that uses uncooked eggs, buy specially pasteurized eggs or use prepared meringue powder.

SEPARATE

Foods that will be eaten uncooked and foods that will be cooked before eating MUST ALWAYS be separated. Cross-contamination occurs when raw meats or eggs come in contact with foods that will be eaten uncooked. This is a major source of food poisoning. Always double-wrap raw meats and place them on the lowest shelf in the refrigerator so there is no way juices can drip onto fresh produce. Then use the raw meats within 1-2 days of purchase, or freeze for longer storage. Defrost frozen meats in the refrigerator, not on the counter.

When grilling or cooking raw meats or fish, make sure to place the cooked meat on a clean platter. Don't use the same platter you used to carry the food out to the grill. Wash the utensils used in grilling after the food is turned for the last time on the grill, as well as spatulas and spoons used for stir-frying or turning meat as it cooks.

Make sure to wash your hands after handling raw meats or raw eggs. Washing hands with soap and water, or using a pre-moistened antibacterial towelette is absolutely necessary after you have touched raw meat or raw eggs. Not washing hands and surfaces while cooking is a major cause of cross-contamination.

CLEAN

Wash your hands and work surfaces frequently when you are cooking. Washing with soap and warm water for at least 15 seconds, then dry with a paper towel.

CHILL

Chilling food is very important. The danger zone where bacteria multiply is between 40°F and 140°F (4°C and 6°C). Your refrigerator should be set to 40°F (4°C) or below; your freezer should be 0°F (-17°C) or below. Simple rule: serve hot foods hot, cold foods cold. Use chafing dishes or hot plates to keep food hot while serving. Use ice water baths to keep cold foods cold. Never let any food sit at room temperature for more than 2 hours - 1 hour if the ambient temperature is 90°F (32°C) or above. When packing for a picnic, make sure the foods are already chilled when they go into the insulated

OUTLET INSTRUCTIONS

This appliance has a polarized plug (one prong is wider than the other). To reduce the risk of electric shock, the plug must fully fit into the electrical outlet. If the plug does not fit, turn it over and try again. If the plug still does not fit, contact a qualified electrician in regards to updating the electrical outlets in your home. DO NOT modify the plug in any way.



DISASSEMBLY & CLEANING INSTRUCTIONS

WARNING! Before cleaning, assembling or disassembling the **Tomato Strainer**, make sure it is turned off "O" and disconnected from the power source. Test to make sure there is no power to the **Motor** by switching the **Motor** on "-" and off "O".

Before using the **Tomato Strainer** for the first time, thoroughly clean all parts (including accessories) as instructed below. **DO NOT** immerse the **Motor** in water or other liquid.

1. Turn the **Motor Unit** off "O" and disconnect it from the power supply.
2. Remove the **Hopper** from the **Head**.
3. Turn the **Head Locking Nut** counter-clockwise to loosen the **Head** from the **Motor**. Push the **Head/Screen Assembly** forward slightly while lifting out the back end of the **Head/Screen Assembly** removing it from the **Motor**.
4. Turn the **Front Ring Nut** counter-clockwise to remove it from the **Head**.
5. Disassemble all the parts from the **Head/Screen Assembly**.
6. Gently turn the **Chute** clockwise to unhook the tabs on the **Motor**.
7. **WARNING! DO NOT** immerse the **Motor** in water or other liquid. Clean the **Motor** with a damp cloth or towel then wipe dry. Wash all parts that contact food in warm soapy water. Rinse with clean water. Dry all parts immediately.
NOTE! Only plastic parts of the **Tomato Strainer** are top-rack dishwasher safe.
8. Coat the **Screens, Head and Drive Shaft Assembly** with a food-grade silicone spray.

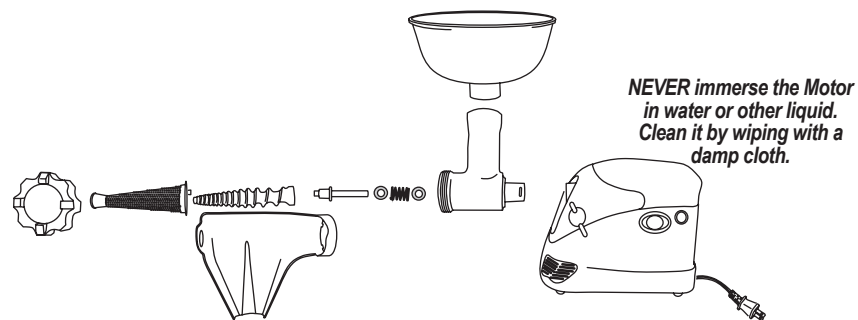

ASSEMBLY

WARNING! Before cleaning, assembling or disassembling the **Tomato Strainer**, make sure it is turned off “O” and disconnected from the power source. Test to make sure there is no power to the **Motor** by switching the **Motor** on “-” and off “O”.

1. Hold the **Chute** with the outlet tilted almost fully downward and the head ring facing the **Motor** (figure 1).

2. Place the head ring of the **Chute** over the round raised face on the front of the **Motor**. Position the tabs on the head ring next to the slots in the corresponding tabs extending from the round face (figure 2).

3. Rotate the **Plastic Chute** counterclockwise until the tabs fit into the slots. The **Plastic Chute** should now be firmly held in place. When properly positioned, the outlet of the **Chute** should dip slightly downward.

4. Equip the round end of the **Drive Shaft** with a **Metal Washer, Spring** and a **Metal Washer**. (figure 3).

5. Insert the square end of the **Drive Shaft** into the corresponding slot in the **Auger** (figure 4).

6. Insert the **Auger/Drive Shaft Assembly** into the **Head**.

7. Position the **Screen** over the **Auger**. Line up the tabs on the **Screen** with the notches in the **Head**. Hold the **Screen** in place.

8. Slide the **Front Ring Nut** over the **Screen** assembly and turn clockwise to firmly tighten (make sure the tabs on the **Screen** remain aligned with the notches on the **Head**). **DO NOT** overtighten the **Front Ring Nut** to avoid damaging the **Motor** during operation.

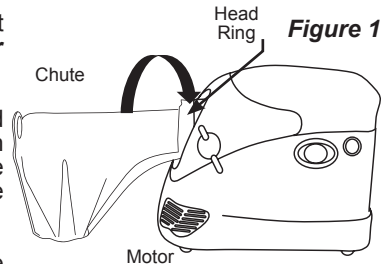

Figure 1

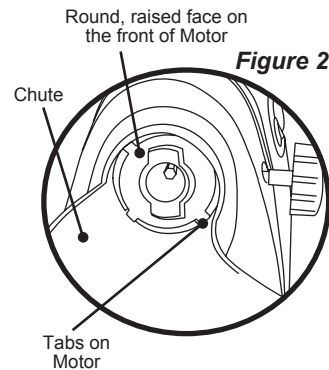

Figure 2

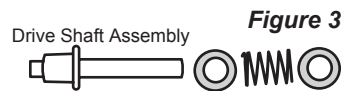

Figure 3

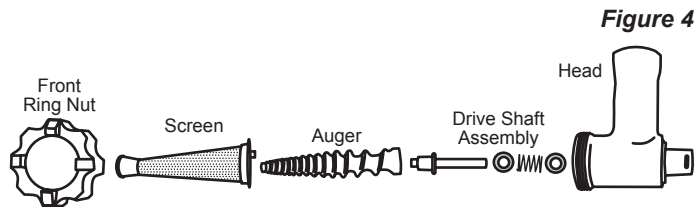

Figure 4

LARGE BATCH ITALIAN TOMATO SAUCE

1/2 cup olive oil	3 medium onions, <i>chopped</i>	2 cloves garlic, <i>minced</i>
3 Tbsp brown sugar	1 Tbsp dried oregano	4 tsp salt
2 tsp dried basil	1 tsp black pepper	12 cups fresh tomato puree

- Heat the olive oil in a large pan
- Sauté the onions and garlic until tender, do not overly brown
- Add the rest of the ingredients
- Bring mixture to a boil, reduce heat and simmer partially covered for 2 hours or until sauce has reduced to desired consistency
- Stir occasionally
- Serve or allow to cool then refrigerate or freeze
- Ingredients like sliced mushrooms, cooked/drained sausage, hamburger, etc. can be added to taste

VEGETABLE JUICE

8 qt fresh tomatoes	8 stalks celery	1/4 cup parsley
3 small onions, <i>finely chopped</i>		1 lemon, <i>juiced</i>
1 leek, only the white part, <i>finely chopped</i>		1/2 tsp allspice
1 Tbsp Worcestershire sauce		1 Tbsp salt
1 cup carrots, <i>finely chopped</i>		black pepper, <i>to taste</i>
1 cup green pepper, <i>finely chopped</i>		hot sauce, <i>optional</i>

- Put tomato pieces along with finely chopped: celery (stalk and leaves), onion, leek, carrot and green pepper along with lemon juice into a large, non-aluminum, pot
- Cook over medium heat for 30 minutes until vegetables are soft
- Once the mixture has cooled, process through the **Tomato Strainer**
- Season with: salt, allspice, Worcestershire sauce and pepper (add hot sauce now if desired)
- Serve chilled

QUICK APPLESAUCE

3 Tbsp butter	6 Macintosh apples	1/4 cup sugar
1 tsp cinnamon	1/2 tsp nutmeg	4 tbsps water

- Steam apples in a covered pot for approximately 15 minutes or until soft
- Allow apples to cool, then run through **Tomato Strainer** using the
- Mix the remainder of the ingredients with the apple puree and chill
- For variety, try different apples or mix them with different apples

DELICIOUS AND HEALTHY APPLE CRISP

2-1/2 cups granola	2 Cups “Quick Applesauce”	
3-1/2 Tbsp brown sugar	1-1/2 Tbsp butter	1-1/2 tsp cinnamon
		whipped cream

- First make 2 cups of Quick Applesauce using the above recipe
- In a buttered baking dish alternate layers of granola with the Quick Applesauce
- End with a layer of granola
- Sprinkle with the cinnamon and brown sugar
- Spread the butter around in small pieces
- Bake in oven at 350°F (176°C) for 20 minutes
- Top off with whipped cream

FRESH & EASY RECIPES

U.S. VOLUME CONVERSIONS		U.S. WEIGHT CONVERSIONS	
1 tsp	5 ml	1 oz	28 g
1 Tbsp	15 ml	1/4 lb or 4 oz	113 g
1/8 cup or 1 fl oz	30 ml	1/3 lb	150 g
1/4 cup or 2 fl oz	60 ml	1/2 lb or 8 oz	230 g
1/3 cup	80 ml	2/3 lb	300 g
1/2 cup or 4 fl oz	120 ml	3/4 lb or 12 oz	340 g
2/3 cup	160 ml	1 lb or 16 oz	450 g
3/4 cup or 6 fl oz	180 ml	2 lb	900 g
1 cup or 8 fl oz or 1/2 pint	240 ml		
1 1/2 cup or 12 fl oz	350 ml		
2 cups or 16 fl oz or 1 pint	475 ml		
3 cups or 1 1/2 pints	700 ml		
4 cups or 2 pints or 1 qt	950 ml		
4 quarts or 1 gal	3.8 L		

LARGE BATCH ITALIAN TOMATO SAUCE

1/2 cup olive oil 3 medium onions, *chopped* 2 cloves garlic, *minced*
 3 Tbsp brown sugar 1 Tbsp dried oregano 4 tsp salt
 2 tsp dried basil 1 tsp black pepper 12 cups fresh tomato puree

- Heat the olive oil in a large pan
- Sauté the onions and garlic until tender, do not overly brown
- Add the rest of the ingredients
- Bring mixture to a boil, reduce heat and simmer partially covered for 2 hours or until sauce has reduced to desired consistency
- Stir occasionally
- Serve or allow to cool then refrigerate or freeze
- Ingredients like sliced mushrooms, cooked/drained sausage, hamburger, etc. can be added to taste

MARINARA SAUCE

1 cup carrots, *finely minced* 6 lbs ripe Italian-style tomato puree
 1 cup onion, *finely minced* 1/2 cup celery, *finely minced*
 1/2 cup olive oil 1 tsp sugar ground white pepper, to taste

Optional seasoning (any one of the following):
 2 tsp ground coriander 1/2-1 tsp dried marjoram 1 tsp dried basil
 1/4 to 1/2 tsp dried oregano 1 to 2 tsp salt

- Heat the olive oil in a large saucepan
- Cover and cook the onions, celery, and carrots over medium-low heat for about 15 minutes, stir occasionally
- Uncover and stir over heat for an additional 5 to 10 minutes, or until the vegetables are soft and slightly golden
- Add the tomato sauce, sugar, and pepper
- Cover and simmer gently for 15 minutes
- Serve or allow to cool then refrigerate or freeze

9. Turn the **Head Locking Knob** counterclockwise to loosen (figure 5).

10. Insert the **Screen** end of the fully-assembled **Screen/Head Assembly** through the outlet end of the **Chute** (figure 5).

11. Slide the **Screen/Head Assembly** horizontally into the **Head** onto the **Motor** (figure 6).

12. Turn the **Head Locking Knob** clockwise to tighten the **Screen/Head Assembly** to the **Motor**.

13. Install the **Hopper** onto the **Head**. Press the **Hopper** down until fully seated (figure 7).

14. **ALWAYS** use the **Stomper** to push food into the **Head/Hopper**, **NEVER** use hands or fingers (figure 8).

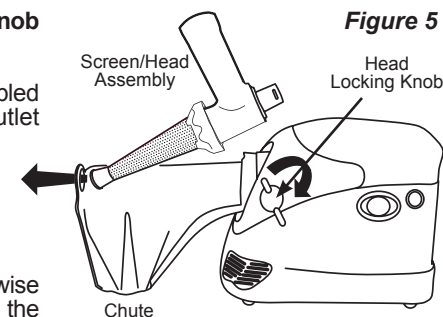

Figure 5

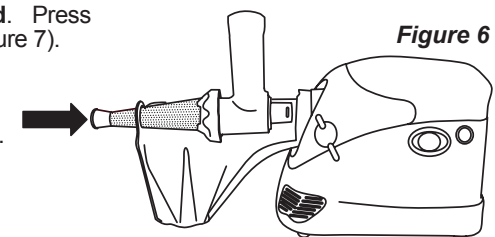

Figure 6

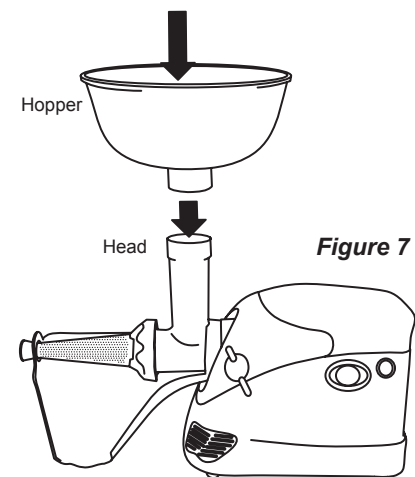

Figure 7

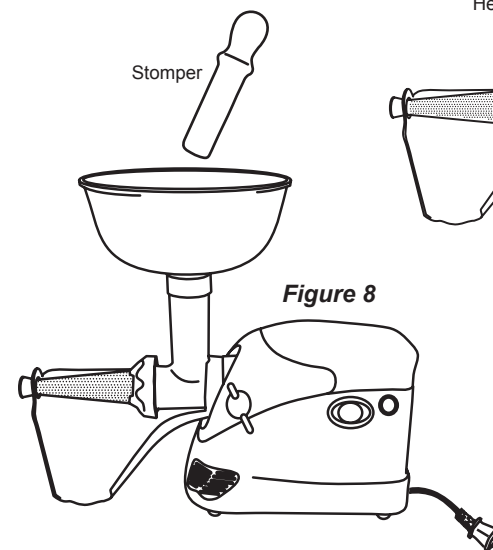

Figure 8

INSTRUCTIONS FOR USE

NOTE: *The Tomato Strainer cannot be used with meat products.*

1. Cut large fruits and vegetables into quarters and small fruits and vegetables in half.

IMPORTANT: Remove pits, stems, hard shells and hard seeds before placing fruits or vegetables into the **Tomato Strainer** to avoid damaging the **Screen**.

2. Be sure the **Power Switch** is in the off "O" position. Connect the power cord for the **Tomato Strainer** to the power source.
3. Place the fruits/vegetables in the **Hopper**. Do not overfill the **Hopper**. **DO NOT** operate the **Tomato Strainer** without the **Hopper** in place.
4. Place a bowl under the **Chute** to collect juice and pulp. Place a bowl under the **Screen** outlet to collect skin and seeds (figure 9).
5. Turn the **Power Switch** to the on "-" position.
6. Feed the fruits/vegetables into the **Head**. Use the **Stomper** to push the fruits/vegetables into the **Head**. **ALWAYS** use the **Stomper** to push food into the **Head/Hopper**, **NEVER** use hands or fingers.

HELPFUL HINTS:

- A. Rerun the skin and seeds through the **Tomato Strainer** to extract any leftover pulp & juice. Repeat as necessary.
 - B. Use a rubber spatula to scrape pulp from the **Screen** into the **Chute**.
7. When straining is complete, turn the **Motor** to the off "O" position and disconnect it from the power source.

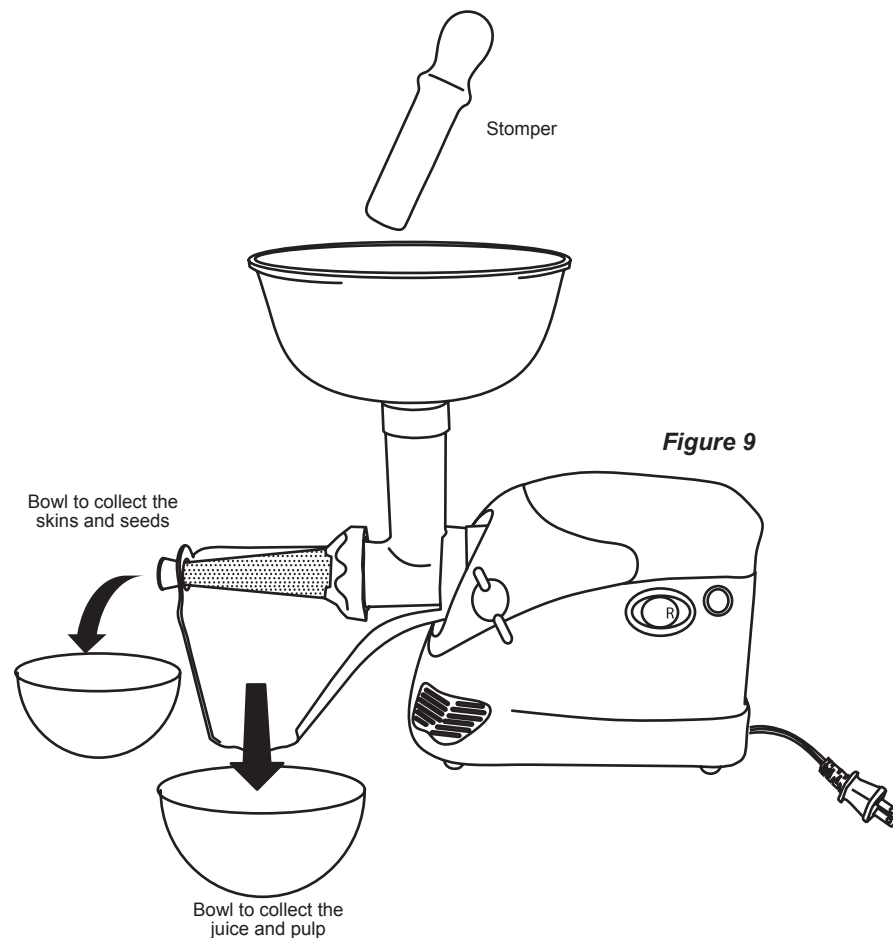

REVERSE FUNCTION

The "**R**" **Reverse Toggle** is used primarily for clearing jams. In event of a jam;

- Turn the **Power Switch** to the off "O" position. Allow the **Motor** to come to a **COMPLETE STOP** before toggling the "**R**" **Reverse Toggle** to clear a jam.
- Allow the **Motor** to come to a **COMPLETE STOP** before turning the **Power Switch** to the on "-" position after using the reverse function.
- **NEVER** operate the **Motor** in reverse for more than 5 seconds at a time.

If the jam does not clear, disconnect the **Tomato Strainer** from the power source and follow the "*Disassembly & Cleaning Instructions*" to clean the unit.

