



**ATTENTION!**

If any components of this unit are broken, do not operate properly, or for product returns, please contact Weston Products LLC  
Phone: 1-800-814-4895 (Outside the U.S. 440-638-3131)  
20365 Progress Drive, Strongsville, Ohio 44149  
WestonProducts.com

*All Trademarks and Registered Trademarks are property of the respective companies.*

**SAVE THESE INSTRUCTIONS!**

*Refer to them often and use them to instruct others.*

**Roma™**  
by **WESTON®**

**Tomato  
Press**

**MODEL NO. 67-1001-W**



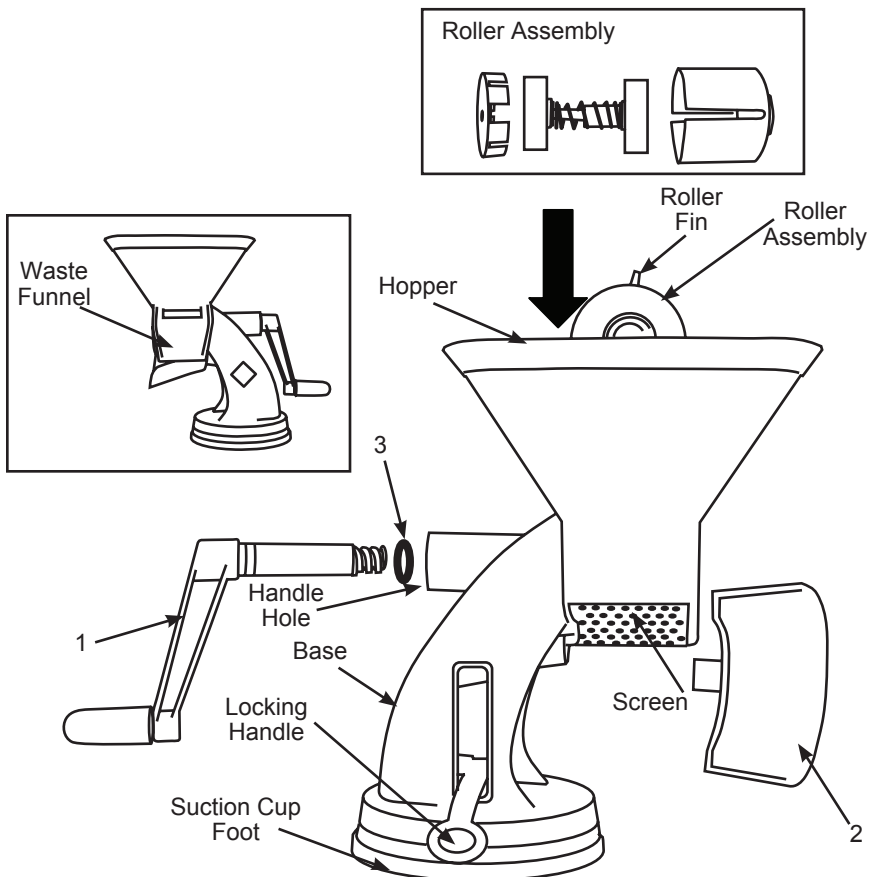

## COMPONENT LIST

DIAGRAM NUMBER	PART DESCRIPTION	PART NUMBER
1	Handle	N/A
2	Juice Chute	N/A
3	Rubber O-Ring (3 (2 spare))	67-0104

If any components of this unit are broken or the unit does not operate properly, call Weston Products LLC Toll Free at

**1-800-814-4895**

Monday thru Friday 8:00am-5:00pm EST. Outside the U.S. call 440-638-3131

**CAUTION!** It is important to follow the "Food Safety" guidelines outlined in this manual. For the most up to date instruction visit the USDA website.

## WESTON WARRANTY INFORMATION

### SAVE THIS WARRANTY INFORMATION FOR YOUR RECORDS!

Weston Products LLC warrants to the ORIGINAL RETAIL PURCHASER of this product that if operated in accordance with the printed instruction accompanying it, then for a period of 1 year from the date of purchase, the product shall be free from defects in material and workmanship.

The Warranty Card, along with a copy of the original receipt, must be received by Weston Products LLC within 30 days from purchase date for the warranty to apply. Failure to send the completely filled out Warranty Card, along with a copy of the original receipt, will void the warranty.

The product must be delivered to or shipped freight prepaid to Weston Products LLC for warranty services, in either its original packaging or similar packaging affording an equal degree of protection. Damage due to shipping is not the responsibility of the company. Weston Products LLC charges a \$35.00 per hour bench charge. **NOTE:** No repairs will be started without the authorization of the customer. The return shipping cost to the customer will be added to the repair invoice.

Weston Products LLC will repair (or at its discretion, replace) the product free of charge, if in the judgment of the company, it has been proven to be defective as to seller's labor and material, within the warranty period.

New or rebuilt replacements for factory defective parts will be supplied for one (1) year from the date of purchase. Replacement parts are warranted for the remainder of the original warranty period.

For non-warranty repairs, contact Weston Products LLC's Customer Service at 1-800-814-4895 M-F 8am-5pm EST (outside of the United States 440-638-3131) to obtain a Return Merchandise Authorization Number (RMA Number). Weston Products LLC will refuse all returns that do not contain this number. **DO NOT RETURN THE UNIT WITHOUT PROPER AUTHORIZATION FROM WESTON PRODUCTS LLC.**

**LIMITATIONS:** The warranty is void if the product is used for any purpose other than that for which it is designed. The product must not have been previously altered, repaired, or serviced by anyone else other than Weston Products LLC. If applicable, the serial number must not have been altered or removed. The product must not have been subjected to accident in transit or while in the customer's possession, misused, abused, or operated contrary to the instructions contained in the instruction manual. This includes failure caused by neglect of reasonable and necessary maintenance, improper line voltage and acts of nature. This warranty is not transferable and applies only to U.S. and Canadian sales.

Except to the extent prohibited by applicable law, no other warranties whether expressed or implied, including warranty merchantability and fitness for a particular purpose, shall apply to this product. Under no circumstances shall Weston Products LLC be liable for consequential damages sustained in connection with said product and Weston Products LLC neither assumes nor authorizes any representative or other person to assume for it any obligation or liability other than such as is expressly set forth herein. Any applicable implied warranties are also limited to the one (1) year period of the limited warranty.

This warranty covers only the product and its specific parts, not the food or other products processed in it.

CUT ALONG THE DOTTED LINE AND SEND THE WARRANTY CARD ALONG WITH A COPY OF YOUR ORIGINAL PURCHASE RECEIPT TO:

**Weston Products LLC**  
**20365 Progress Drive, Strongsville, OH 44149**

## WESTON WARRANTY CARD

SEND THIS CARD ALONG WITH A COPY OF YOUR ORIGINAL PURCHASE RECEIPT TO:  
 WESTON WARRANTY, WESTON PRODUCTS LLC, 20365 PROGRESS DRIVE, STRONGSVILLE, OH 44149

Customer Name: \_\_\_\_\_

Address: \_\_\_\_\_

City/State/Zip: \_\_\_\_\_

Telephone Number: (\_\_\_\_\_) \_\_\_\_\_

E-Mail Address: \_\_\_\_\_

Original Date of Purchase: \_\_\_\_/\_\_\_\_/\_\_\_\_

Product Model #: \_\_\_\_\_

Serial # (if applicable): \_\_\_\_\_



## FOOD SAFETY

There are basic rules to follow when handling food. They are **COOK, SEPARATE, CLEAN, and CHILL.**

### COOK

It's crucial to cook food to a safe internal temperature to destroy bacteria that is present. The safety of hamburgers and other foods made with ground meat has been receiving a lot of attention lately, and with good reason. When meat is ground, the bacteria present on the surface is mixed throughout the ground mixture. If this ground meat is not cooked to at least 160°F to 165°F, bacteria will not be destroyed and there's a good chance you will get sick.

Solid pieces of meat like steaks and chops don't have dangerous bacteria like E. coli on the inside, so they can be served more rare. Still, any beef cut should be cooked to an internal temperature of at least 145°F (medium rare). The safe temperature for poultry is 180°F and solid cuts of pork should be cooked to 160°F. Eggs should be thoroughly cooked too. If you are making a meringue or other recipe that uses uncooked eggs, buy specially pasteurized eggs or use prepared meringue powder.

### SEPARATE

Foods that will be eaten uncooked and foods that will be cooked before eating **MUST ALWAYS** be separated. Cross-contamination occurs when raw meats or eggs come in contact with foods that will be eaten uncooked. This is a major source of food poisoning. Always double-wrap raw meats and place them on the lowest shelf in the refrigerator so there is no way juices can drip onto fresh produce. Then use the raw meats within 1-2 days of purchase, or freeze for longer storage. Defrost frozen meats in the refrigerator, not on the counter.

When grilling or cooking raw meats or fish, make sure to place the cooked meat on a clean platter. Don't use the same platter you used to carry the food out to the grill. Wash the utensils used in grilling after the food is turned for the last time on the grill, as well as spatulas and spoons used for stir-frying or turning meat as it cooks.

Make sure to wash your hands after handling raw meats or raw eggs. Washing hands with soap and water, or using a pre-moistened antibacterial towelette is absolutely necessary after you have touched raw meat or raw eggs. Not washing hands and surfaces while cooking is a major cause of cross-contamination.

### CLEAN

Wash your hands and work surfaces frequently when you are cooking. Washing with soap and warm water for at least 15 seconds, then dry with a paper towel.

### CHILL

Chilling food is very important. The danger zone where bacteria multiply is between 40°F and 140°F. Your refrigerator should be set to 40°F or below; your freezer should be 0°F or below. Simple rule: serve hot foods hot, cold foods cold. Use chafing dishes or hot plates to keep food hot while serving. Use ice water baths to keep cold foods cold. Never let any food sit at room temperature for more than 2 hours - 1 hour if the ambient temperature is 90°F or above. When packing for a picnic, make sure the foods are already chilled when they go into the insulated hamper. The hamper won't chill food - it just keeps food cold when properly packed with ice. Hot cooked foods should be placed in shallow containers and immediately refrigerated so they cool rapidly. Make sure to cover foods after they are cool.

NOTE: Special considerations must be made when using venison or other wild game, since it can become heavily contaminated during field dressing. Venison is often held at temperatures that could potentially allow bacteria to grow, such as when it is being transported. Refer to the USDA Meat and Poultry Department for further questions or information on meat and food safety.

## GENERAL SAFETY RULES



**READ AND FULLY UNDERSTAND ALL INSTRUCTIONS AND WARNINGS PRIOR TO USING THIS UNIT. YOUR SAFETY IS MOST IMPORTANT! FAILURE TO COMPLY WITH PROCEDURES AND SAFE GUARDS MAY RESULT IN SERIOUS INJURY OR PROPERTY DAMAGE. REMEMBER: YOUR PERSONAL SAFETY IS YOUR RESPONSIBILITY!**

1. Read all instructions before using the **Tomato Press**.
2. **DO NOT** leave the **Tomato Press** unattended. Close supervision is necessary used near children. This appliance is **NOT** to be used by children.
3. The use of attachments from other manufactures is not recommended, personal injury or damage to the **Tomato Press** may result.
4. **DO NOT** put your fingers or hands into **Tomato Press**, serious injury may result.
5. Thoroughly clean all parts that will come into contact with food before you use the **Tomato Press** for the first time. The **Tomato Press** is top-rack dishwasher safe.
6. Check for damaged parts before using the **Tomato Press**. Ensure that all parts are working correctly.
7. The manufacturer declines any responsibility in case of improper use of this product.
8. This product is not intended for commercial use. Commercial use will void the warranty.
9. **DO NOT** use fingers to scrape material away from the screen. Gently use a rubber spatula or wooden spoon.
10. **WEAR EYE PROTECTION!** Wear safety glasses. Everyday eye glasses are **NOT** safety glasses. Safety Glasses conform to ANSI Z87.1 requirements. NOTE: Approved safety glasses have "Z87" printed or stamped on them.
11. **DO NOT** use the **Tomato Press** while under the influence of drugs, medications or alcohol.
12. **TIE BACK** loose hair and clothing, and roll up long sleeves before operating the strainer. **REMOVE** ties, rings, watches, bracelets or other jewelry before operating the **Tomato Press**.
13. Keep fingers clear of the **Roller Assembly** and **Screen** at all times.

## SAVE THESE INSTRUCTIONS!

*Refer to them often and use them to instruct others.*

## CLEANING INSTRUCTIONS

Before using the **Tomato Press** for the first time, and after every use, the unit must be completely disassembled and cleaned with hot, soapy water. Rinse with clear. Dry immediately. The **Tomato Press** is top-rack dishwasher safe.

For hard to reach areas, we recommend using a soft bristle brush.

For cleaning the **Screen**, it is highly recommended to wear heavy, sturdy gloves, such as Kevlar Cut Resistant Gloves; failure to do so may cause personal injury.



## DISASSEMBLY INSTRUCTIONS

To disassemble the **Tomato Press**, please follow the simple steps listed below:

1. Remove the **Juice Chute** by gently pulling it straight out from the **Base**.
2. Remove the **Handle**, by turning it counter-clockwise until it un-threads from the **Roller Assembly**.
3. Reach into the **Hopper** to remove the **Roller Assembly**. **NOTE: DO NOT** reach into the **Hopper UNLESS** the **Handle** has been **REMOVED!** *Failure to follow this warning may cause severe injury!*
4. While holding the **Roller Assembly**, pinch the **Roller Fins** and slide them out of the channel. This will also release the **Cap**, allowing the **Roller Fins** and **Spring** to be removed from the housing.
5. Disassemble the **Roller Fins** and **Spring**.
6. The **Tomato Press** is now completely disassembled and ready to be cleaned.

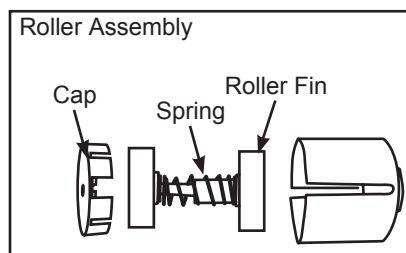

## ASSEMBLY INSTRUCTIONS

To assemble the **Tomato Press**, please follow these simple steps:

1. Dampen the rubber **Suction Cup** on the **Base** and press it onto a smooth, level working surface. **NOTE:** When positioning, make sure the **Suction Cup Locking Arm** is in the raised position.
2. Hold the **Base** and push the **Suction Cup Locking Arm** to the down position.
3. Install the **Roller Assembly** into the **Base**. Make sure the threaded portion lines up with the **Handle Hole**.
4. Insert the **Handle**, with the **O-Ring** installed onto the shaft, into the **Handle Hole** and turn the **Handle** clockwise to secure it to the **Roller Assembly**.
5. Attach the **Juice Chute** to the **Body** by positioning the tab on the **Juice Chute** into the notch in the **Body** under the **Screen**.
6. Once assembly is complete, try to move **Tomato Press**. If there is any movement, repeat steps 1 and 2.
7. **Tomato Press** is now ready for use.

## RECIPES

U.S. VOLUME CONVERSIONS		U.S. WEIGHT CONVERSIONS	
1 tsp	5 ml	1 oz	28 g
1 Tbsp	15 ml	1/4 lb or 4 oz	113 g
1/8 cup or 1 fl oz	30 ml	1/2 lb or 8 oz	230 g
1/4 cup or 2 fl oz	60 ml	2/3 lb	300 g
1/3 cup	80 ml	3/4 lb or 12 oz	340 g
1/2 cup or 4 fl oz	120 ml	1 lb or 16 oz	450 g
2/3 cup	160 ml	2 lb	900 g
3/4 cup or 6 fl oz	180 ml		
1 cup or 8 fl oz or 1/2 pint	240 ml		
1 1/2 cup or 12 fl oz	350 ml		
2 cups or 16 fl oz or 1 pint	475 ml		
3 cups or 1 1/2 pints	750 ml		
4 cups or 2 pints or 1 qt	950 ml		
4 quarts or 1 gal	3.8 L		

**NOTE:** The **Tomato Press** works great with soft fruits and vegetables. Firm or hard fruits and vegetable will need to be cooked to soften prior to straining.

### ITALIAN TOMATO SAUCE

2 lb plum tomatoes      1/2 cup extra-virgin olive oil      1/4 cup chopped white onions  
1/4 cup finely chopped celery      1 tsp sugar      1 Tbsp fine sea salt

- Core and quarter the tomatoes, then run them through **Tomato Press** to yield fresh tomato puree.
- Heat the olive oil over a medium heat in a large pan.
- Add the onions and celery and sauté until tender, do not overly brown.
- Add the rest of the ingredients.
- Bring mixture to a boil, reduce heat and simmer.
- Stir occasionally.
- Simmer until sauce has thickened, 15 to 20 minutes.

### QUICK APPLESAUCE

3 Tbsp butter      6 Macintosh apples      1/4 cup sugar  
1 tsp cinnamon      1/2 tsp nutmeg      4 Tbsp water

- Steam apples in a covered pot for approximately 15 minutes or until soft.
- Allow apples to cool.
- Core and quarter the apples then run them through **Tomato Press**
- Mix the remainder of the ingredients with the apple puree and chill.