



ATTENTION!

If any components of this unit are broken, do not operate properly, or for product returns, please contact Weston Products LLC
Phone: 1-800-814-4895 (Outside the U.S. 440-638-3131)
20365 Progress Drive, Strongsville, Ohio 44149
WestonProducts.com

All Trademarks and Registered Trademarks are property of the respective companies.

SAVE THESE INSTRUCTIONS!

Refer to them often and use them to instruct others.



Bucatini, Mezze Penne, Tortiglioni, Rigatoni & Fusilli

**Tube
Pasta Machine**

MODEL NO. 01-0701-W



REV032911

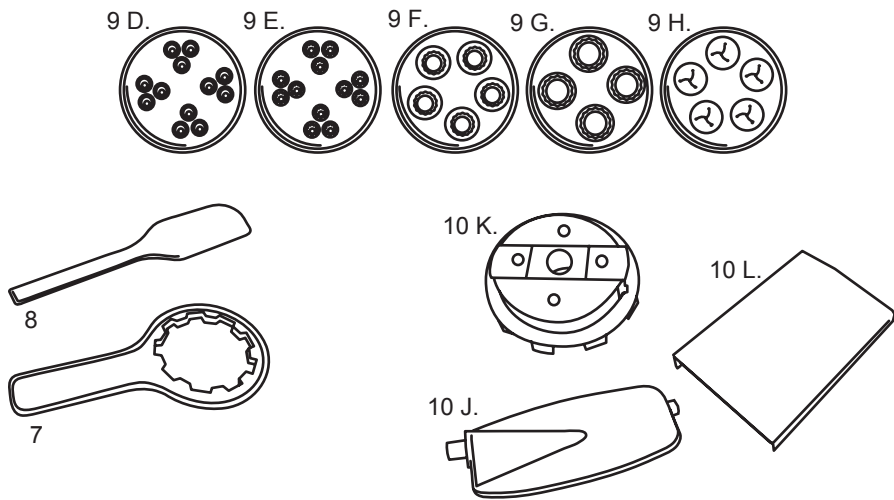
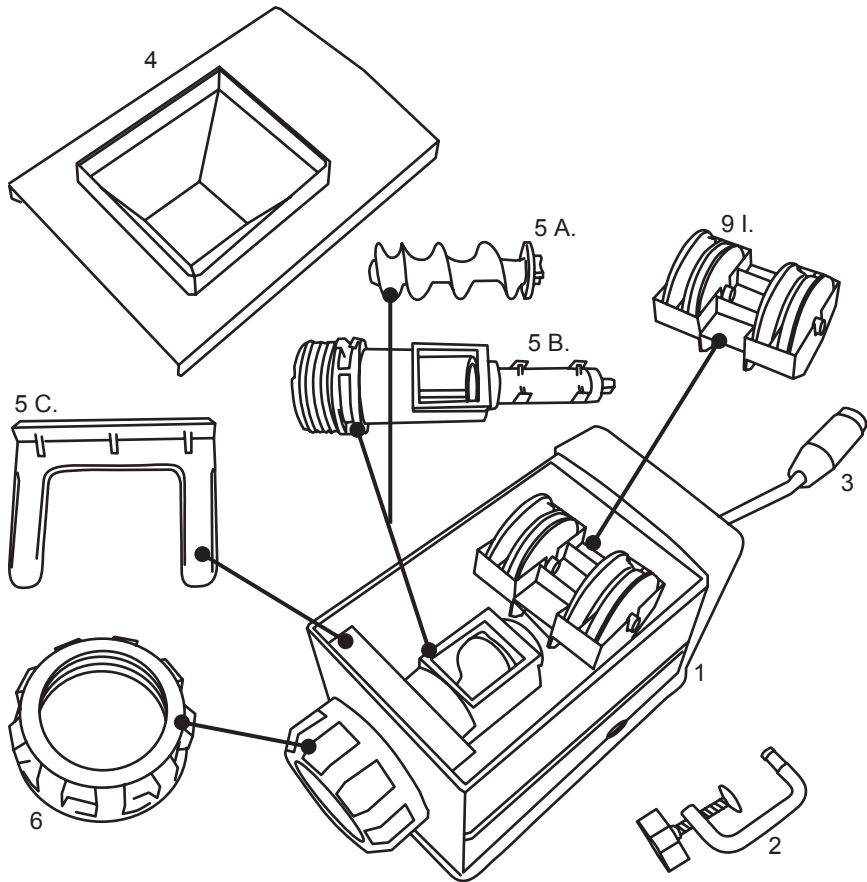

WESTON WARRANTY INFORMATION

SAVE THIS WARRANTY INFORMATION FOR YOUR RECORDS!

Weston Products LLC warrants to the ORIGINAL RETAIL PURCHASER of this product that if operated in accordance with the printed instruction accompanying it, then for a period of 1 year from the date of purchase, the product shall be free from defects in material and workmanship.

The Warranty Card, along with a copy of the original receipt, must be received by Weston Products LLC within 30 days from purchase date for the warranty to apply. Failure to send the completely filled out Warranty Card, along with a copy of the original receipt, will void the warranty.

The product must be delivered to or shipped freight prepaid to Weston Products LLC for warranty services, in either its original packaging or similar packaging affording an equal degree of protection. Damage due to shipping is not the responsibility of the company. Weston Products LLC charges a \$35.00 per hour bench charge. **NOTE:** No repairs will be started without the authorization of the customer. The return shipping cost to the customer will be added to the repair invoice.

Weston Products LLC will repair (or at its discretion, replace) the product free of charge, if in the judgment of the company, it has been proven to be defective as to seller's labor and material, within the warranty period.

New or rebuilt replacements for factory defective parts will be supplied for one (1) year from the date of purchase. Replacement parts are warranted for the remainder of the original warranty period.

For non-warranty repairs, contact Weston Products LLC's Customer Service at 1-800-814-4895 M-F 8am-5pm EST (outside of the United States 440-638-3131) to obtain a Return Merchandise Authorization Number (RMA Number). Weston Products LLC will refuse all returns that do not contain this number. **DO NOT RETURN THE UNIT WITHOUT PROPER AUTHORIZATION FROM WESTON PRODUCTS LLC.**

LIMITATIONS: The warranty is void if the product is used for any purpose other than that for which it is designed. The product must not have been previously altered, repaired, or serviced by anyone else other than Weston Products LLC. If applicable, the serial number must not have been altered or removed. The product must not have been subjected to accident in transit or while in the customer's possession, misused, abused, or operated contrary to the instructions contained in the instruction manual. This includes failure caused by neglect of reasonable and necessary maintenance, improper line voltage and acts of nature. This warranty is not transferable and applies only to U.S. and Canadian sales.

Except to the extent prohibited by applicable law, no other warranties whether expressed or implied, including warranty merchantability and fitness for a particular purpose, shall apply to this product. Under no circumstances shall Weston Products LLC be liable for consequential damages sustained in connection with said product and Weston Products LLC neither assumes nor authorizes any representative or other person to assume for it any obligation or liability other than such as is expressly set forth herein. Any applicable implied warranties are also limited to the one (1) year period of the limited warranty.

This warranty covers only the product and its specific parts, not the food or other products processed in it.

CUT ALONG THE DOTTED LINE AND SEND THE WARRANTY CARD ALONG WITH A COPY OF YOUR ORIGINAL PURCHASE RECEIPT TO:

Weston Products LLC
20365 Progress Drive, Strongsville, OH 44149

WESTON WARRANTY CARD

SEND THIS CARD ALONG WITH A COPY OF YOUR ORIGINAL PURCHASE RECEIPT TO:
 WESTON WARRANTY, WESTON PRODUCTS LLC, 20365 PROGRESS DRIVE, STRONGSVILLE, OH 44149

Customer Name: _____

Address: _____

City/State/Zip: _____

Telephone Number: (_____) _____

E-Mail Address: _____

Original Date of Purchase: ____/____/____

Product Model #: _____

Serial # (if applicable): _____



FOOD SAFETY

There are basic rules to follow when handling food. They are **COOK, SEPARATE, CLEAN,** and **CHILL.**

COOK

It's crucial to cook food to a safe internal temperature to destroy bacteria that is present. The safety of hamburgers and other foods made with ground meat has been receiving a lot of attention lately, and with good reason. When meat is ground, the bacteria present on the surface is mixed throughout the ground mixture. If this ground meat is not cooked to at least 160°F to 165°F (71°C to 74°C), bacteria will not be destroyed and there's a good chance you will get sick.

Solid pieces of meat like steaks and chops don't have dangerous bacteria like E. coli on the inside, so they can be served more rare. Still, any beef cut should be cooked to an internal temperature of at least 145°F (63°C) (medium rare). The safe temperature for poultry is 180°F (82°C) and solid cuts of pork should be cooked to 160°F (71°C). Eggs should be thoroughly cooked too. If you are making a meringue or other recipe that uses uncooked eggs, buy specially pasteurized eggs or use prepared meringue powder.

SEPARATE

Foods that will be eaten uncooked and foods that will be cooked before eating **MUST ALWAYS** be separated. Cross-contamination occurs when raw meats or eggs come in contact with foods that will be eaten uncooked. This is a major source of food poisoning. Always double-wrap raw meats and place them on the lowest shelf in the refrigerator so there is no way juices can drip onto fresh produce. Then use the raw meats within 1-2 days of purchase, or freeze for longer storage. Defrost frozen meats in the refrigerator, not on the counter.

When grilling or cooking raw meats or fish, make sure to place the cooked meat on a clean platter. Don't use the same platter you used to carry the food out to the grill. Wash the utensils used in grilling after the food is turned for the last time on the grill, as well as spatulas and spoons used for stir-frying or turning meat as it cooks.

Make sure to wash your hands after handling raw meats or raw eggs. Washing hands with soap and water, or using a pre-moistened antibacterial towelette is absolutely necessary after you have touched raw meat or raw eggs. Not washing hands and surfaces while cooking is a major cause of cross-contamination.

CLEAN

Wash your hands and work surfaces frequently when you are cooking. Washing with soap and warm water for at least 15 seconds, then dry with a paper towel.

CHILL

Chilling food is very important. The danger zone where bacteria multiply is between 40°F and 140°F (4°C and 6°C). Your refrigerator should be set to 40°F (4°C) or below; your freezer should be 0°F (-17°C) or below. Simple rule: serve hot foods hot, cold foods cold. Use chafing dishes or hot plates to keep food hot while serving. Use ice water baths to keep cold foods cold. Never let any food sit at room temperature for more than 2 hours - 1 hour if the ambient temperature is 90°F (32°C) or above. When packing for a picnic, make sure the foods are already chilled when they go into the insulated hamper. The hamper won't chill food - it just keeps food cold when properly packed with ice. Hot cooked foods should be placed in shallow containers and immediately refrigerated so they cool rapidly. Make sure to cover foods after they are cool.

NOTE: Special considerations must be made when using venison or other wild game, since it can become heavily contaminated during field dressing. Venison is often held at temperatures that could potentially allow bacteria to grow, such as when it is being transported. Refer to the USDA Meat and Poultry Department for further questions or information on meat and food safety.

CAUTION! It is important to follow the "Food Safety" guidelines outlined in this manual. For the most up to date instruction visit the USDA website.

COMPONENT LIST

DIAGRAM NUMBER	PART DESCRIPTION	PART NUMBER
1	Pasta Machine Body	N/A
2	C-Clamp	01-0217
3	Handle	01-0216
4	Pasta Lid	01-0705
5	Auger Assembly	01-0703
	A. Auger	
	B. Auger Housing	
	C. Auger Lock	
6	Front Ring Nut	01-0706
7	Ring Nut Wrench	01-0707
8	Cutter Spatula	01-0708
9	Disc Kit	01-0704
	D. Bucatini Disc	
	E. Mezze Penne Disc	
	F. Tortiglioni Disc	
	G. Rigatoni Disc	
	H. Fusilli Disc	
	I. Disc Rack	
<i>Not Shown</i>	Rubber Foot (4)	01-0211
10	Mixing Kit	01-0702
	J. Mixing Paddle	
	K. Front Cap	
	L. Enclosed Mixer Lid	

If any components of this unit are broken or the unit does not operate properly, call Weston Products LLC Toll Free at

1-800-814-4895

Monday thru Friday 8:00am-5:00pm EST. Outside the U.S. call 440-638-3131

ADDITIONAL ACCESSORIES AVAILABLE

PART DESCRIPTION	PART NUMBER
Traditional Pasta Machine	01-0201
Deluxe Electric Pasta machine	01-0601-W
5.5 Quart Stainless Steel Colander	66-0105-W
Food Strainer & Sauce Maker	07-0801
Deluxe Electric Tomato Strainer	82-0202-W

These products and many more products can be ordered by visiting WestonProducts.com or by calling Weston Products LLC Toll Free at 1-800-814-4895 Monday thru Friday 8:00am-5:00pm EST. Outside the U.S. call 440-638-3131

DISASSEMBLY & CLEANING

1. Remove the **Handle** from the driver.
2. Open the **C-Clamp** all the way open by turning the handle of the **C-Clamp** counter-clockwise.
3. Remove the **Pasta Lid** by gently pulling up from one side, popping the **Pasta Lid** off. If using the **Mixer Lid**, slide the **Mixer Lid** off.
4. Remove any left over dough in the **Pasta Machine**.
5. Twist the **Front Ring Nut** or the **Front Cap** counter-clockwise and remove. If the **Front Ring Nut** or the **Front Cap** is too tight, place the **Ring Nut Wrench** over the **Front Ring Nut** or the **Front Cap** and twist counter-clockwise to loosen it.
6. Remove all parts from the **Pasta Machine**.
7. Once all parts are removed, lay them all out and let the dough dry for a few hours.
8. Use a dry pastry brush to remove any dough from the parts.
9. Wash all of the parts in warm, soapy water. Rinse with clear water and dry. **NEVER WASH THE PASTA MACHINE or its parts in the dishwasher.** It is best NOT to immerse the **Pasta Machine Body** into water/liquids. Wash and rinse the **Body** and let air dry completely. Some water may enter the openings of the **Body**, simply allow the water to run out and dry.
10. Reassemble the dry unit following the “*Assembly Instructions*” as outlined in this manual.

SPINACH PASTA DOUGH

3 cups flour
1/4 tsp salt
8 oz fresh spinach

2 eggs
1-3 cup water

1 Tbsp olive oil

- Remove the stems from 8 oz. of fresh spinach
- Cook the spinach in boiling water for about 2 minutes or until the spinach is wilted
- Rinse the spinach to cool it quickly
- Squeeze the spinach dry, then puree it in a blender. Add the 2 eggs to the pureed spinach and blend well
- Add all of the pasta dough ingredients to the Body of the Pasta Machine.
- Turn the Handle at a consistent pace to mix the ingredients together.
- Follow the “*Mixing Dough*” instructions as outlined in this manual.

TOMATO SAUCE

2-1/4 lb peeled tomatoes
chopped parsley
small bunch fresh basil

1 small onion, chopped
1 stalk celery chopped
1/4 cup oil

1 carrot, shredded
salt & pepper

- Put the peeled tomatoes in a saucepan with the oil, vegetables and herbs
- Cook at moderate heat for about half an hour with the lid on
- Remove the lid and simmer to allow sauce to thicken, add salt to taste

ARRABIATA SAUCE

1 tsp olive oil
1 Tbsp chopped fresh basil
1/2 tsp Italian seasoning
1 cup chopped onion
1/4 tsp ground black pepper

4 cloves minced garlic
2 Tbsp tomato paste
2 Tbsp chopped parsley
1 Tbsp crushed red pepper flakes
19 oz cans peeled and diced tomatoes

1 Tbsp white sugar
1 Tbsp lemon juice
3/8 cup red wine

- Heat oil in a large skillet or saucepan over medium heat
- Sauté onion and garlic in oil for 5 minutes
- Stir in wine, sugar, basil, red pepper, tomato paste, lemon juice, Italian seasoning, black pepper and tomatoes; bring to a boil
- Reduce heat to medium, and simmer uncovered about 15 minutes
- Stir in parsley

BÉCHAMEL SAUCE

1-3/4 oz butter
2-1/4 cups milk

1-3/4 oz flour
nutmeg

salt

- Warm milk in a small saucepan
- Put the butter in a saucepan at moderate heat and when it melts, add the flour and cook slowly for a few minutes
- Stir continuously, without letting it brown
- Add the warmed milk to the butter and flour mixture in small doses
- Smooth out any lumps with a whisk or a wooden spoon

MIXING DOUGH

1. Slide open the **Mixer Lid** (figure E).
2. Add all of the pasta dough ingredients to the **Body** of the **Pasta Machine**.
3. Slide the **Mixer Lid** closed.
4. Turn the **Handle** at a consistent pace to mix the ingredients together. If the mixture is wet, slowly add a little flour; if the mixture is dry, slowly add a little water.
5. Continue mixing until the dough has a consistent color and texture.
6. Remove the dough from the **Pasta Machine**. Form the dough into a mound shape and cover with a damp towel.
7. It is important to let the dough now rest for 10-15 minutes to allow the ingredients to blend together.
8. After dough has rested, cut off a piece approximately 1/4" (0.6 cm) thick, re-cover remaining dough with damp towel until needed.
9. Follow the "*Pasta Machine Assembly*" and "*Making Pasta*" instructions as outlined in this manual.

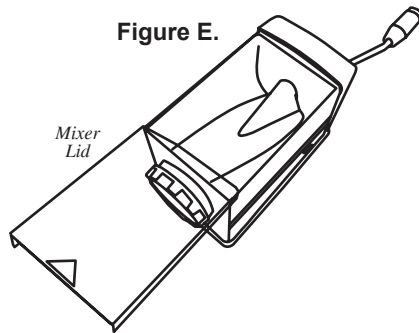

COOKING THE PASTA

Whenever cooking pasta, keep the following points in mind:

- Always use plenty of boiling water so the pasta does not stick.
- One-half pound of noodles will require at least 2 quarts of water, 1 pound of pasta will require 6 quarts.
- Add 1 tsp of salt for each quart of water.
- Always bring the water to a full, rolling boil before adding pasta or it will not cook properly.
- Cooking time will vary based on the size, weight and ingredients of the noodles.
- Homemade noodles take very little time to cook and should be tested after 3-4 minutes.
- Pasta should be cooked al dente. This means it should not be mushy, but tender, yet slightly hard to bite. Test the pasta frequently to test for doneness.
- It is better that the noodles be slightly under-cooked than overcooked.
- Once pasta is cooked, drain it but never rinse.
- For the best pasta dishes, add sauce to the drained noodles and serve immediately.

CAUTION! It is important to follow the "Food Safety" guidelines outlined in this manual. For the most up to date instruction visit the USDA website.

MAKING PASTA

1. Turn the **Handle** clockwise while feeding a piece of dough through the **Pasta Lid** and into the **Auger**.

2. At a consistent pace, keep turning the **Handle**.

3. The pasta will begin to extrude out of the **Pasta Disc**. Once the pasta reaches the desired length, cut the pasta off of the **Pasta Disc** using the **Cutter Spatula** (figure L).

4. Repeat this process for the remaining dough.

5. Lay the cut pasta on a cheesecloth or non-stick surface and let it dry for about an hour.

If making pasta to store, extra drying time is needed.

CAUTION! It is important to follow the "Food Safety" guidelines outlined in this manual. For the most up to date instruction visit the USDA website.

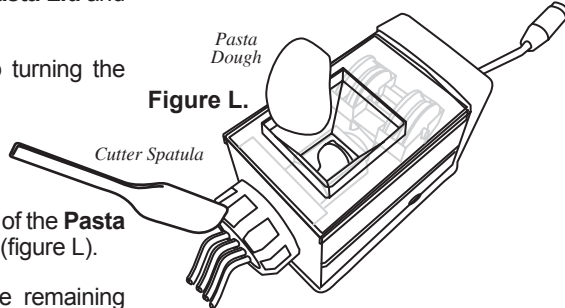

Figure L.

WARNING!
KEEP FINGERS OUT OF THE CHUTE OF THE PASTA LID!
NEVER TOUCH THE AUGER WHILE IN USE OR WHILE THE AUGER IS IN MOTION.



PASTA MACHINE ASSEMBLY

Before using the **Pasta Machine**, clean all parts as outlined in the "Cleaning Instructions" in this booklet.

1. Insert the metal hexagon end of the **Auger Housing** into the opening of the **Pasta Machine Body** and into the metal hexagon opening inside the back of the **Body** (figure F).

2. Insert the "+" end of the **Auger** inside of the **Auger Housing**. Align the "+" of the **Auger** with the "+" inside the **Auger Housing**. Make sure the **Auger** is fully seated inside the **Auger Housing**.

3. Align the **Auger Lock** up with the channels inside the **Body**, on each side of the **Auger Housing**. Slide the **Auger Lock** into the channels, locking the **Auger Housing** into place.

4. Place the **Pasta Disc** of choice, metal side facing outwards, into the **Front Ring Nut**. There are 4 tabs on the **Pasta Disc** the need to align with 4 notches on the **Auger Housing**. **NOTE:** Each **Pasta Disc** is made of two pieces. Be sure the plastic portion is lined up with the metal portion of the **Pasta Disc**.

5. By turning the **Front Ring Nut** in a clockwise direction, screw the **Front Ring Nut** onto the **Auger Housing**. Make sure the **Front Ring Nut** is snug, but do not overtighten. NEVER use the **Ring Nut Wrench** to tighten the **Front Ring Nut**, damage to the machine may occur.

6. Optional: Place the unused **Pasta Discs** into the **Disc Rack** and place into the brackets on the top of the **Auger Housing** (figure G).

7. Align the funnel hole in the **Pasta Lid** with the opening on the **Auger Housing**. Gently snap the **Pasta Lid** onto the **Pasta Machine Body** (figure I).

8. Insert the end of the **Handle** into the "Slow" (for pasta making) ("Fast" for mixing dough) drive on the back of the **Body** (figure H).

Figure F.

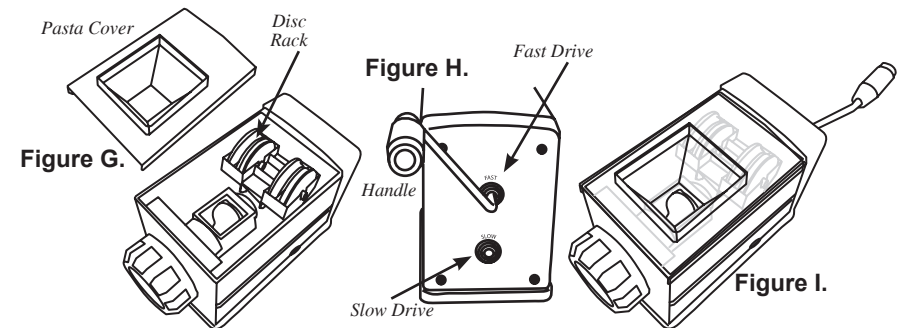
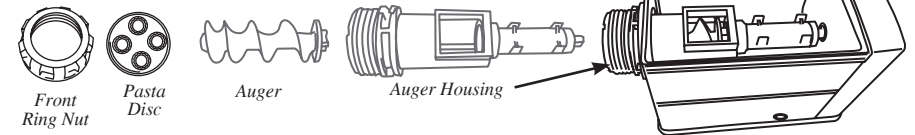

9. Open the **C-Clamp** all the way open by turning the handle of the **C-Clamp** counter-clockwise. Attach the **Pasta Machine** to a table or countertop by inserting the end of the **C-Clamp** into the opening on the side of the **Pasta Machine Body** (figure J.). Turn the handle of the **C-Clamp** clockwise to tighten the vice onto the counter.

NOTE: Make sure the **Handle** of the **Pasta Machine** is able to turn freely before tightening the **C-Clamp**.

Make sure the **Pasta Machine** is sturdy and tight onto the countertop.

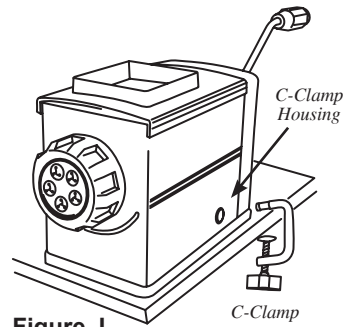

Figure J.

CHANGING THE PASTA DISC

1. Turn the **Handle** a half of a turn counter-clockwise to reverse the dough in the **Auger** a bit.
2. If the **Disc Rack** and the **Pasta Discs** are stored inside the **Pasta Machine Body**, remove the **Pasta Lid** by gently pulling up from one side, popping the **Pasta Lid** off.
3. Twist the **Front Ring Nut** counter-clockwise and remove. If the **Front Ring Nut** is too tight, place the **Ring Nut Wrench** over the **Front Ring Nut** and twist counter-clockwise to loosen the **Front Ring Nut** (figure K).
4. Remove the **Pasta Disc**.
5. Place the **Pasta Disc** of choice, metal side facing outwards, into the **Front Ring Nut**. There are 4 tabs on the **Pasta Disc** the need to align with 4 notches on the **Auger Housing**. **NOTE:** Each **Pasta Disc** is made of two pieces. Be sure the plastic portion is lined up with the metal portion of the **Pasta Disc**.
6. By turning the **Front Ring Nut** in a clockwise direction, screw the **Front Ring Nut** onto the **Auger Housing**. Make sure the **Front Ring Nut** is snug, but do not overtighten. NEVER use the **Ring Nut Wrench** to tighten the **Front Ring Nut**, damage to the machine may occur.

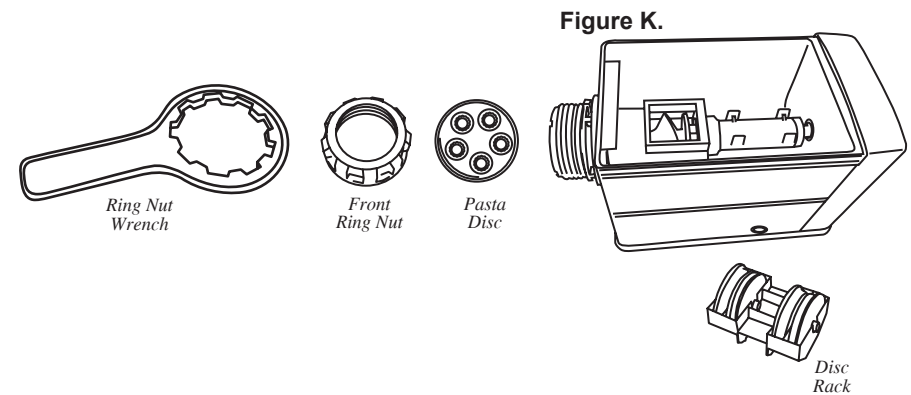

Figure K.