



**ATTENTION!**

If any components of this unit are broken, do not operate properly,  
or for product returns, please contact Weston Products LLC at

**1-800-814-4895**

*(Outside the U.S. call 440-638-3131).*

For the online catalog, log onto [WestonSupply.com](http://WestonSupply.com).

*Exclusively imported by Weston Products LLC Strongsville, Ohio*

**SAVE THESE INSTRUCTIONS!**

*Refer to them often and use them to instruct others.*



**STAINLESS STEEL**

**CONE**

**STRAINER**

**& PESTLE SET**

**MODEL NO. 83-3030-W**



REV030410



**STAINLESS STEEL  
CONE  
STRAINER  
& PESTLE SET**

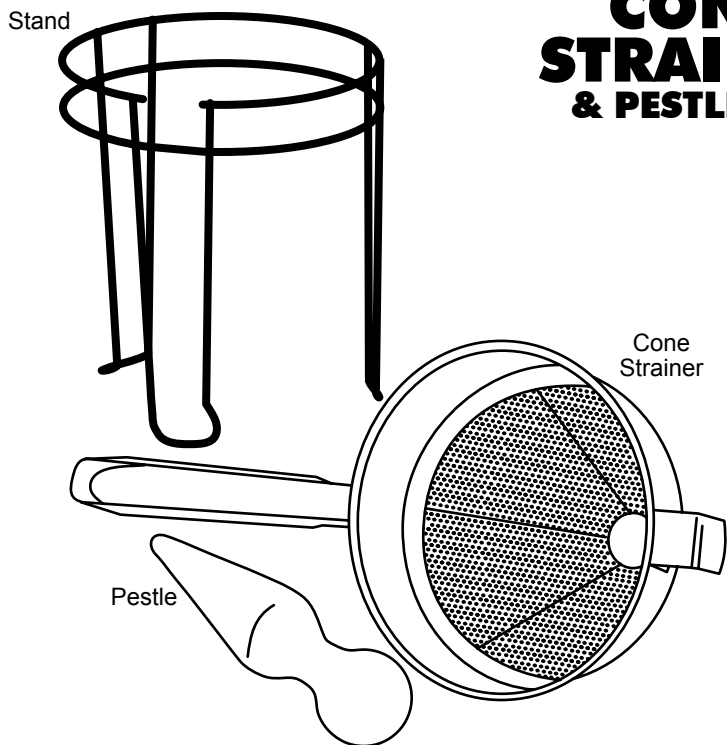

If any components of this unit are broken or the unit does not operate properly, call Weston Products LLC Toll Free at  
**1-800-814-4895**  
 Monday thru Friday 8:00am-5:00pm EST. Outside the U.S. call 440-638-3131

**ADDITIONAL ACCESSORIES AVAILABLE**

Deluxe 5-Piece Canning Kit	83-2017-W
Manual Pasta Machine	01-0201
10 Tray Food Dehydrator	75-0201-W

These products and many more products can be ordered by visiting  
**WestonSupply.com** or by calling  
 Weston Products LLC Toll Free at 1-800-814-4895  
 Monday thru Friday 8:00am-5:00pm EST. Outside the U.S. call 440-638-3131

**WESTON WARRANTY INFORMATION**  
**SAVE THIS WARRANTY INFORMATION FOR YOUR RECORDS!**

Weston Products LLC warrants to the ORIGINAL RETAIL PURCHASER of this product that if operated in accordance with the printed instruction accompanying it, then for a period of 1 year from the date of purchase, the product shall be free from defects in material and workmanship.

The Warranty Card, along with a copy of the original receipt, must be received by Weston Products LLC within 30 days from purchase date for the warranty to apply. Failure to send the completely filled out Warranty Card, along with a copy of the original receipt, will void the warranty.

The product must be delivered to or shipped freight prepaid to Weston Products LLC for warranty services, in either its original packaging or similar packaging affording an equal degree of protection. Damage due to shipping is not the responsibility of the company. Weston Products LLC charges a \$35.00 per hour bench charge. **NOTE:** No repairs will be started without the authorization of the customer. The return shipping cost to the customer will be added to the repair invoice.

Weston Products LLC will repair (or at its discretion, replace) the product free of charge, if in the judgment of the company, it has been proven to be defective as to seller's labor and material, within the warranty period.

New or rebuilt replacements for factory defective parts will be supplied for one (1) year from the date of purchase. Replacement parts are warranted for the remainder of the original warranty period.

For non-warranty repairs, contact Weston Products LLC's Customer Service at 1-800-814-4895 M-F 8am-5pm EST (outside of the United States 440-638-3131) to obtain a Return Merchandise Authorization Number (RMA Number). Weston Products LLC will refuse all returns that do not contain this number. **DO NOT RETURN THE UNIT WITHOUT PROPER AUTHORIZATION FROM WESTON PRODUCTS LLC.**

**LIMITATIONS:** The warranty is void if the product is used for any purpose other than that for which it is designed. The product must not have been previously altered, repaired, or serviced by anyone else other than Weston Products LLC. If applicable, the serial number must not have been altered or removed. The product must not have been subjected to accident in transit or while in the customer's possession, misused, abused, or operated contrary to the instructions contained in the instruction manual. This includes failure caused by neglect of reasonable and necessary maintenance, improper line voltage and acts of nature. This warranty is not transferable and applies only to U.S. and Canadian sales.

Except to the extent prohibited by applicable law, no other warranties whether expressed or implied, including warranty merchantability and fitness for a particular purpose, shall apply to this product. Under no circumstances shall Weston Products LLC be liable for consequential damages sustained in connection with said product and Weston Products LLC neither assumes nor authorizes any representative or other person to assume for it any obligation or liability other than such as is expressly set forth herein. Any applicable implied warranties are also limited to the one (1) year period of the limited warranty.

This warranty covers only the product and its specific parts, not the food or other products processed in it.

CUT ALONG THE DOTTED LINE AND SEND THE WARRANTY CARD ALONG WITH A COPY OF YOUR ORIGINAL PURCHASE RECEIPT TO:

**Weston Products LLC**  
**20365 Progress Drive, Strongsville, OH 44149**

**WESTON WARRANTY CARD**

SEND THIS CARD ALONG WITH A COPY OF YOUR ORIGINAL PURCHASE RECEIPT TO:  
 WESTON WARRANTY, WESTON PRODUCTS LLC, 20365 PROGRESS DRIVE, STRONGSVILLE, OH 44149

Customer Name: \_\_\_\_\_

Address: \_\_\_\_\_

City/State/Zip: \_\_\_\_\_

Telephone Number: (\_\_\_\_\_) \_\_\_\_\_

E-Mail Address: \_\_\_\_\_

Original Date of Purchase: \_\_\_\_/\_\_\_\_/\_\_\_\_

Product Model #: \_\_\_\_\_

Serial # (if applicable): \_\_\_\_\_



## VELVET ROASTED TOMATO SOUP

2 1/2 lb fresh tomatoes (use a variety of heirlooms, cherry, vine & plum tomatoes)

6 cloves garlic, peeled

2 small yellow onions, sliced

1/2 cup extra-virgin olive oil

Salt & freshly ground black pepper

1 qt chicken stock

2 bay leaves

4 Tbsp butter

1/2 cup chopped fresh basil leaves, optional

3/4 cup heavy cream

Cherry tomatoes

- Wash, core and cut tomatoes into halves
- Spread the tomatoes, garlic and onions onto a baking tray
- Drizzle with the olive oil and season with salt and pepper
- Roast in a pre-heated oven at 450°F (232°C) for 20 to 30 minutes, or until soft and browned
- Remove roasted tomatoes, garlic and onion from the oven
- Set aside the cherry tomatoes
- Transfer the roasted tomato mixture into a large stock pot
- Add 3 cups of the chicken stock, bay leaves, and butter to the tomatoes
- Bring to a boil, reduce heat and simmer for 15 to 20 minutes or until liquid has reduced by a third
- Carefully place the soup, cup by cup through the **Cone Strainer**, using the **Pestle**, smash the mixture through until smooth
- Discard any skins and seeds left inside the **Cone Strainer**
- Return strained soup to low heat, add cream and adjust consistency with remaining chicken stock, if necessary
- Season to taste with salt and pepper
- Garnish in bowl with 3 or 4 roasted vine cherry tomatoes and a splash of heavy cream

## SWEET POTATO APPLE BABY FOOD (4-6 MONTHS)

sweet potatoes

apples

- Wash and poke holes in sweet potato with fork then wrap sweet potatoes in tin foil
- Wash apples and quarter, spread out on a cookie sheet
- Place the sweet potatoes and apples in a 400°F (204°C) oven and bake for 30-60 minutes or until soft
- Remove the sweet potato skins by slitting the sweet potato lengthwise when cooled then scoop out
- Carefully place the potatoes and the apples through the **Cone Strainer**, using the **Pestle**, smash the mixture through until smooth
- Discard any skins and seeds left inside the **Cone Strainer**
- Use a water or formula to thin the mixture

## HOW TO JUICE A POMEGRANATE

- Cut off the crown of the pomegranate and gently scoop out some of the center core without disturbing the seeds
- With a sharp knife, score just through the outer rind around the fruit in quarters
- Put your thumb in the core center and gently pull apart the sections
- Peel away the inner white papery skin covering the seeds and discard
- Gently invert the skin inside out and the seeds will pop out to be easily removed without bruising
- Place the seeds through the **Cone Strainer**, using the **Pestle**, smash the seeds through until all the juice is out
- Discard any skins and seeds left inside the **Cone Strainer**

## ASSEMBLY & INSTRUCTIONS

**PRIOR TO USING:** It is best to pre-soften some foods prior to use. If the food is firm like potatoes, apples or pears, remember to soften them by steaming or baking to tenderness before using them in the **Strainer**.

1. Place the **Strainer** on the **Stand** (figure 1), the **Handle** will sit into the notch in the **Stand**.

2. Place a bowl under the **Strainer** (figure 1).

3. Place the pointy end of the **Pestle** straight down into the **Strainer** until it hits the bottom (figure 2).

4. Place the food to be processed into the **Strainer** (figure 3). Be sure to only fill the **Strainer** half way.

5. Hold the **Handle** of the **Strainer** with one hand. Hold the round portion of the **Pestle** with the other hand and roll the **Pestle** around the rim of the **Strainer** (figure 4).

6. The mashed food will fall through the perforations and into the bowl (figure 5). It may be necessary to scrape food off of the outside of the **Strainer** into the bowl using a rubber spatula.

7. Discard any skin, seeds or fiber left in the **Strainer** after mashing is complete.

8. It is best to clean the **Strainer** immediately after use to prevent food from drying in the holes of the **Strainer**.

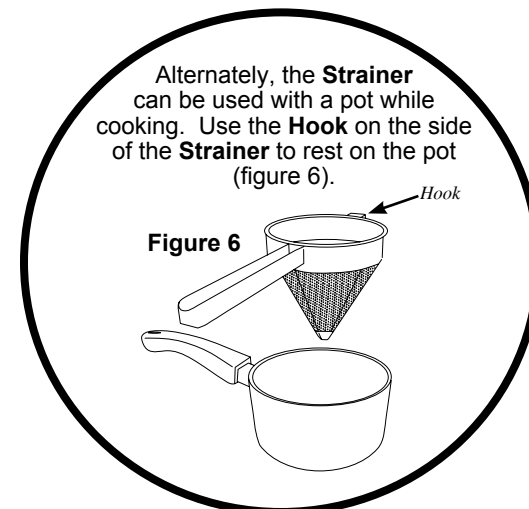
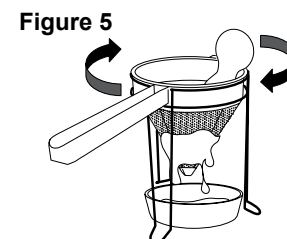
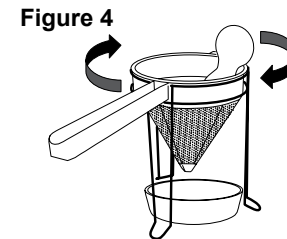
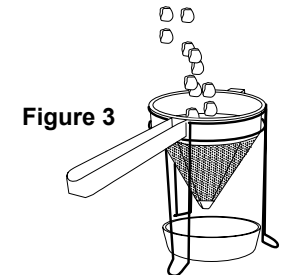
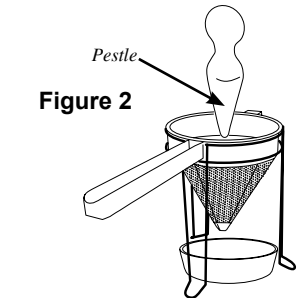
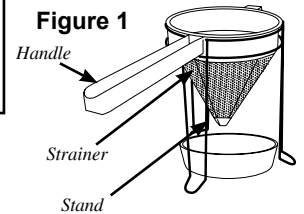

## CLEANING

- It is best to clean the **Strainer** immediately after use to prevent food from drying in the holes of the **Strainer**.

- To clean, from the outside of the **Strainer**, flush away the particles with a strong stream of warm water (figure 3). A fine bristle brush with warm, dish-soap water should be used to gently remove any remaining residue, starting on the inside of the **Strainer** then moving to the outside areas. Flush the **Strainer** with warm, clean water and dry immediately.

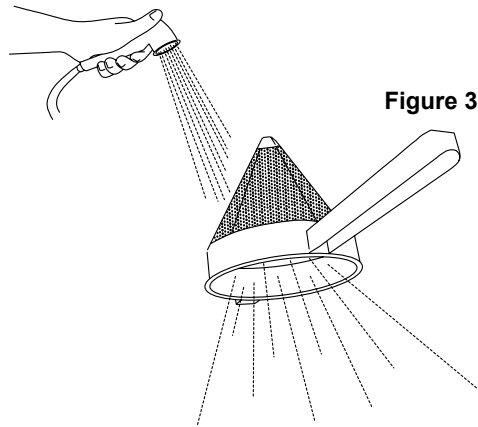

- Gently clean the **Stand** and **Pestle** with warm, dish-soap water and a soft cloth. Rinse with warm, clean water and dry immediately.

- Store the **Strainer**, **Stand** and **Pestle** in the box in a clean, dry area to prevent damage to the product.

- The **Strainer** is dishwasher safe.

- The **Stand** and **Pestle** are NOT dishwasher safe.

## RECIPES

### U.S. VOLUME CONVERSIONS

1 tsp	5 ml
1 Tbsp	15 ml
1/8 cup or 1 fl oz	30 ml
1/4 cup or 2 fl oz	60 ml
1/3 cup	80 ml
1/2 cup or 4 fl oz	120 ml
2/3 cup	160 ml
3/4 cup or 6 fl oz	180 ml
1 cup or 8 fl oz or 1/2 pint	240 ml
1 1/2 cup or 12 fl oz	350 ml
2 cups or 16 fl oz or 1 pint	475 ml
3 cups or 1 1/2 pints	700 ml
4 cups or 2 pints or 1 qt	950 ml
4 quarts or 1 gal	3.8 L

### U.S. WEIGHT CONVERSIONS

1 oz	28 g
1/4 lb or 4 oz	113 g
1/3 lb	150 g
1/2 lb or 8 oz	230 g
2/3 lb	300 g
3/4 lb or 12 oz	340 g
1 lb or 16 oz	450 g
2 lb	900 g

**PRIOR TO USING:** It is best to pre-soften some foods prior to use. If the food is firm like potatoes, apples or pears, remember to soften them by steaming or baking to tenderness before using them in the **Strainer**.

### SOUR CREAM MASHED POTATOES

3 lb Yukon Gold potatoes

1 1/2 cups milk

6 Tbsp unsalted butter

1/2 cup sour cream

Salt & freshly ground black pepper

- Peel and cube the potatoes into 1" (2.5 cm) cubes
- Place the cubed potatoes into a large pot
- Cover the potatoes with cold water and add enough salt so the water tastes salty
- Bring to a boil, then lower the heat and simmer, uncovered, for about 10 to 12 minutes, until the potatoes fall apart easily when pierced with a fork
- Heat the milk and butter in a small saucepan, making sure it does not boil
- Set the milk and butter aside
- When tender, drain the potatoes
- Place small amounts of the potatoes into the **Cone Strainer**, using the **Pestle**, smash all the potatoes through until smooth
- In a large bowl, slowly whisk in enough of the hot milk/butter mixture to the potatoes to make them very creamy
- Whisk in the sour cream
- Season to taste with salt and pepper

### STRAWBERRY JAM

2 lb fresh strawberries

4 cups white sugar

1/4 cup lemon juice

- Place small amounts of the strawberries into the **Cone Strainer**, using the **Pestle**, smash all the strawberries through until smooth
- Discard any seeds and stems left inside the **Cone Strainer**
- This should yield about 4 cups of mashed strawberries
- In a heavy bottomed saucepan, mix together the strawberries, sugar, and lemon juice
- Stir over low heat until the sugar is dissolved
- Increase heat to high, and bring the mixture to a full rolling boil
- Boil, stirring often, until the mixture reaches 220°F (105°C)
- Transfer to hot sterile jars, leaving 1/4" - 1/2" (0.6 - 1.3 cm) headspace and seal
- Process any unsealed jars in a water bath
- If the jam is going to be eaten right away, don't bother with processing, just refrigerate

**CANNING HINT:** Place 3 plates in a freezer... after about 10 minutes of boiling place a tsp of the liquid of the jam onto the cold plate. Return to freezer for a minute. Run your finger through the jam on the plate... if it doesn't try to run back together (if you can make a line through it with your finger and it stays) it's ready to be canned!