



**ATTENTION**

If any components of this unit are broken,  
do not operate properly, or for product returns,  
please contact PragoTrade Inc. at

**1-800-814-4895**

*Outside the U.S. call 440-638-3131.*

For the online catalog, log onto [www.westonsupply.com](http://www.westonsupply.com).

*Exclusively imported by PragoTrade Inc. Strongsville, Ohio*  
[www.pragoTrade.com](http://www.pragoTrade.com)

**WESTON**  
BRAND

**44 lb (20 kg) / 110 lb (50 kg)**  
**Stainless Steel**

**FLAT TOP SCALE**  
**INSTRUCTIONS**

**44 lb MODEL #24-0302**

**110 lb MODEL #24-0401-W**





**44 lb (20 kg) / 110 lb (50 kg)  
Stainless Steel  
FLAT TOP SCALE**

44 lb MODEL #24-0302  
110 lb MODEL #24-0401-W

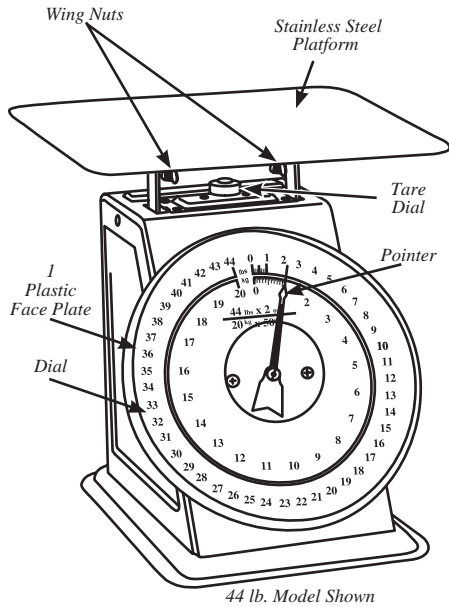

**TO CLEAN THE SCALE**  
Thoroughly wipe clean with a soft damp cloth and mild detergent. Wipe with clear water and dry immediately. **DO NOT IMMERSER THE SCALE IN WATER OR LIQUIDS.**

**ASSEMBLY  
INSTRUCTIONS**

Before using the **Flat Top Scale** for the first time, you must attach the **Platform** onto the top of the **Scale**.

1. Begin by removing the cardboard support from the top of the **Scale**.
2. Attach the **Platform** to the top of the **Scale** with the included **Wing Nuts**.
3. **DO NOT** over-tighten the **Wing Nuts** to prevent damaging the threads.

**HOW TO ZERO  
THE SCALE**

After attaching the **Platform** to the top of the **Scale**, the **Pointer** may not indicate "0" weight. You will need to set the **Pointer** to the "0" position for the **Scale** to accurately indicate an object's weight.

To zero the **Scale**, rotate the **Tare Dial** either clockwise or counter-clockwise (depending on the direction in which the **Pointer** is off) until the **Pointer** indicates "0" weight.

The **Platform** is to be empty while zeroing the **Scale**.

To ensure accurate weight, make sure the **Pointer** is set to "0" before weighing an object.

To weigh objects in a container, place an empty container on the **Platform** then rotate the **Tare Dial** to zero the **Scale**. The **Scale** will now only indicate the weight of objects added to the container.

**WARRANTY INFORMATION**  
SAVE THIS WARRANTY INFORMATION FOR YOUR RECORDS!

Pragotrade Inc. warrants to the ORIGINAL RETAIL PURCHASER of this product that if operated in accordance with the printed instruction accompanying it, then for a period of 1 year from the date of purchase, the product shall be free from defects in material and workmanship.

The Warranty Card, along with a copy of the original receipt, must be received by Pragotrade Inc. within 30 days from purchase date for the warranty to apply. Failure to send the completely filled out Warranty Card, along with a copy of the original receipt, will void the warranty.

The product must be delivered to or shipped freight prepaid to Pragotrade Inc. for warranty services, in either its original packaging or similar packaging affording an equal degree of protection. Damage due to shipping is not the responsibility of the company. Pragotrade Inc. charges a \$35.00 per hour bench charge. NOTE: No repairs will be started without the authorization of the customer. The return shipping cost to the customer will be added to the repair invoice.

Pragotrade Inc. will repair (or at its discretion, replace) the product free of charge, if in the judgment of the company, it has been proven to be defective as to seller's labor and material, within the warranty period.

New or rebuilt replacements for factory defective parts will be supplied for one (1) year from the date of purchase. Replacement parts are warranted for the remainder of the original warranty period.

For non-warranty repairs, contact Pragotrade's Customer Service at 1-800-814-4895 M-F 8am-5pm EST (outside of the United States 440-638-3131) to obtain a Return Authorization Number (RMA Number). Pragotrade will refuse all returns that do not contain this number. **DO NOT RETURN THE UNIT WITHOUT PROPER AUTHORIZATION FROM PRAGOTRADE INC.**

**LIMITATIONS:** The warranty is void if the product is used for any purpose other than that for which it is designed. The product must not have been previously altered, repaired, or serviced by anyone else other than Pragotrade Inc. If applicable, the serial number must not have been altered or removed. The product must not have been subjected to accident in transit or while in the customer's possession, misused, abused, or operated contrary to the instructions contained in the instruction manual. This includes failure caused by neglect of reasonable and necessary maintenance, improper line voltage and acts of nature. This warranty is not transferable and applies only to U.S. and Canadian sales.

Except to the extent prohibited by applicable law, no other warranties whether expressed or implied, including warranty merchantability and fitness for a particular purpose, shall apply to this product. Under no circumstances shall Pragotrade Inc. be liable for consequential damages sustained in connection with said product and Pragotrade Inc. neither assumes nor authorizes any representative or other person to assume for it any obligation or liability other than such as is expressly set forth herein. Any applicable implied warranties are also limited to the one (1) year period of the limited warranty.

This warranty covers only the product and its specific parts, not the food or other products processed in it. **CUT ALONG THE DOTTED LINE AND SEND THE WARRANTY CARD ALONG WITH A COPY OF YOUR ORIGINAL PURCHASE RECEIPT TO:**

**Pragotrade Inc.**  
20365 Progress Drive, Strongsville, OH 44149

**WARRANTY CARD**

SEND THIS CARD ALONG WITH A COPY OF YOUR ORIGINAL PURCHASE RECEIPT

Customer Name: \_\_\_\_\_

Address: \_\_\_\_\_

City/State/Zip: \_\_\_\_\_

Telephone Number: (\_\_\_\_\_) \_\_\_\_\_

E-Mail Address: \_\_\_\_\_

Original Date of Purchase: \_\_\_\_/\_\_\_\_/\_\_\_\_

Product Model #: \_\_\_\_\_

Serial # (if applicable): \_\_\_\_\_

**COMPONENT LIST**

DIAGRAM NUMBER	PART DESCRIPTION	44 lb. PART NO.	110 lb. PART NO.
1	Plastic Face Plate	24-0303	24-0403

If any components of this unit are broken or the unit does not operate properly, call Pragotrade Inc. Toll Free at

**1-800-814-4895**

Monday thru Friday 8:00am-5:00pm EST.  
Outside the U.S. call 440-638-3131