



ATTENTION!

If any components of this unit are broken, do not operate properly,
or for product returns, please contact Weston Products LLC at

1-800-814-4895

(Outside the U.S. call 440-638-3131).

For the online catalog, log onto WestonSupply.com.

Exclusively imported by Weston Products LLC Strongsville, Ohio

SAVE THESE INSTRUCTIONS!

Refer to them often and use them to instruct others.



**DELUXE HEAVY-DUTY
MEAT GRINDER
& SAUSAGE STUFFER
INSTRUCTIONS**

**# 8 Model No.
36-0801-W**

**#10 Model No.
36-1001-W**

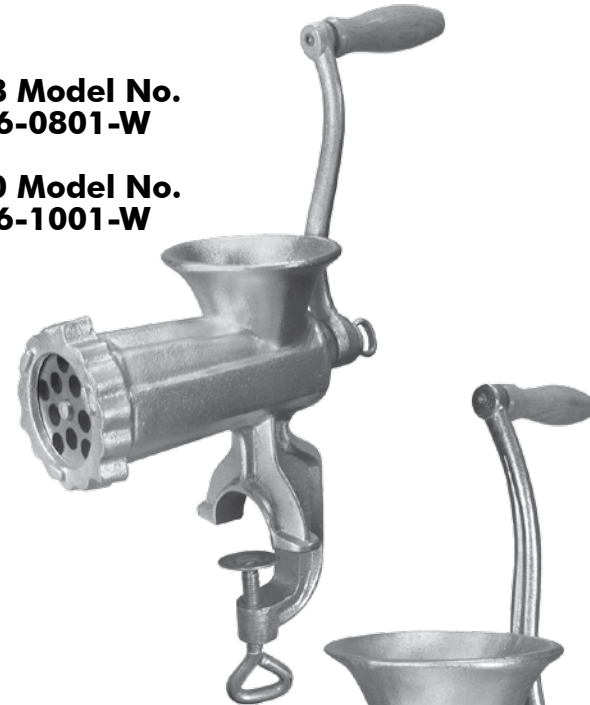

**#22 Model No.
36-2201-W**

**#32 Model No.
36-3201-W**





DELUXE HEAVY-DUTY MEAT GRINDER & SAUSAGE STUFFER

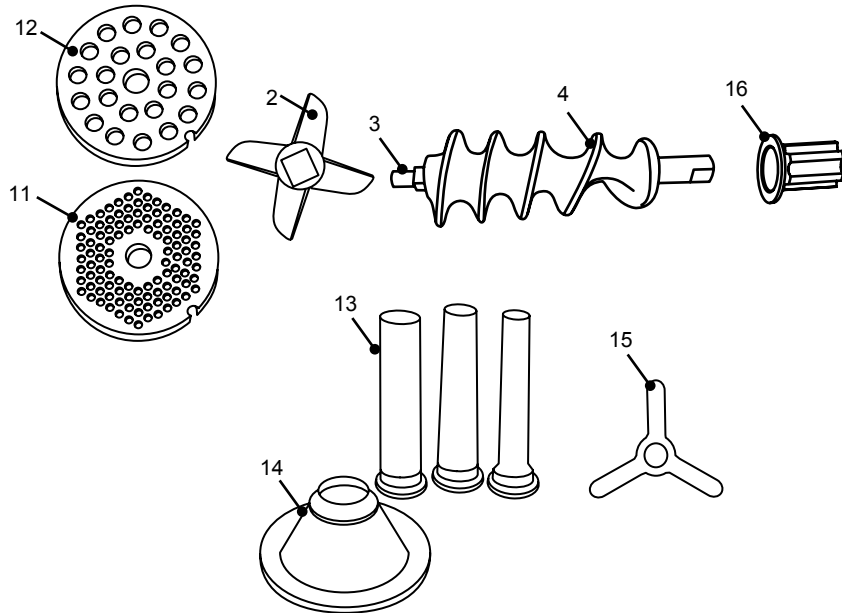

8 Model No.
36-0801-W

#10 Model No.
36-1001-W

#22 Model No.
36-2201-W

#32 Model No.
36-3201-W

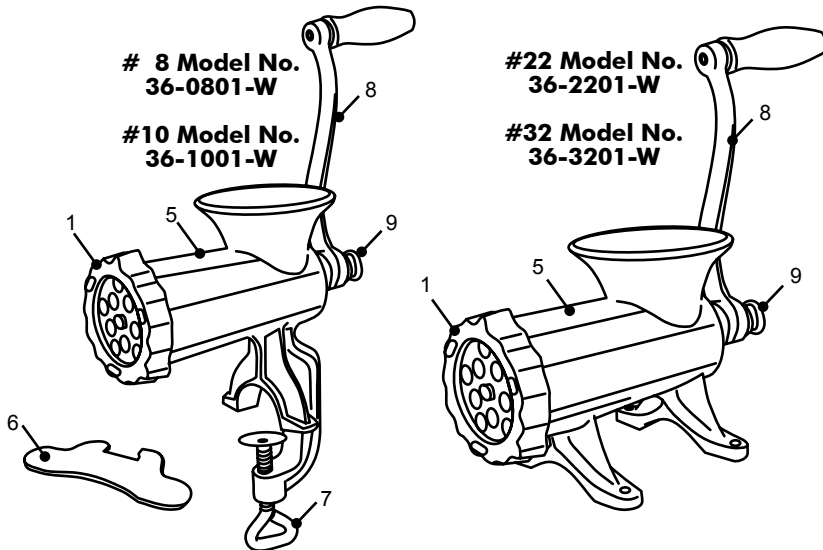

WESTON WARRANTY INFORMATION SAVE THIS WARRANTY INFORMATION FOR YOUR RECORDS!

Weston Products LLC warrants to the ORIGINAL RETAIL PURCHASER of this product that if operated in accordance with the printed instruction accompanying it, then for a period of 1 year from the date of purchase, the product shall be free from defects in material and workmanship.

The Warranty Card, along with a copy of the original receipt, must be received by Weston Products LLC within 30 days from purchase date for the warranty to apply. Failure to send the completely filled out Warranty Card, along with a copy of the original receipt, will void the warranty.

The product must be delivered to or shipped freight prepaid to Weston Products LLC for warranty services, in either its original packaging or similar packaging affording an equal degree of protection. Damage due to shipping is not the responsibility of the company. Weston Products LLC charges a \$35.00 per hour bench charge. **NOTE:** No repairs will be started without the authorization of the customer. The return shipping cost to the customer will be added to the repair invoice.

Weston Products LLC will repair (or at its discretion, replace) the product free of charge, if in the judgment of the company, it has been proven to be defective as to seller's labor and material, within the warranty period.

New or rebuilt replacements for factory defective parts will be supplied for one (1) year from the date of purchase. Replacement parts are warranted for the remainder of the original warranty period.

For non-warranty repairs, contact Weston Products LLC's Customer Service at 1-800-814-4895 M-F 8am-5pm EST (outside of the United States 440-638-3131) to obtain a Return Merchandise Authorization Number (RMA Number). Weston Products LLC will refuse all returns that do not contain this number. **DO NOT RETURN THE UNIT WITHOUT PROPER AUTHORIZATION FROM WESTON PRODUCTS LLC.**

LIMITATIONS: The warranty is void if the product is used for any purpose other than that for which it is designed. The product must not have been previously altered, repaired, or serviced by anyone else other than Weston Products LLC. If applicable, the serial number must not have been altered or removed. The product must not have been subjected to accident in transit or while in the customer's possession, misused, abused, or operated contrary to the instructions contained in the instruction manual. This includes failure caused by neglect of reasonable and necessary maintenance, improper line voltage and acts of nature. This warranty is not transferable and applies only to U.S. and Canadian sales.

Except to the extent prohibited by applicable law, no other warranties whether expressed or implied, including warranty merchantability and fitness for a particular purpose, shall apply to this product. Under no circumstances shall Weston Products LLC be liable for consequential damages sustained in connection with said product and Weston Products LLC neither assumes nor authorizes any representative or other person to assume for it any obligation or liability other than such as is expressly set forth herein. Any applicable implied warranties are also limited to the one (1) year period of the limited warranty.

This warranty covers only the product and its specific parts, not the food or other products processed in it.

CUT ALONG THE DOTTED LINE AND SEND THE WARRANTY CARD ALONG WITH A COPY OF YOUR ORIGINAL PURCHASE RECEIPT TO:

Weston Products LLC
20365 Progress Drive, Strongsville, OH 44149

WESTON WARRANTY CARD

SEND THIS CARD ALONG WITH A COPY OF YOUR ORIGINAL PURCHASE RECEIPT TO:
WESTON WARRANTY, WESTON PRODUCTS LLC, 20365 PROGRESS DRIVE, STRONGSVILLE, OH 44149

Customer Name: _____
Address: _____
City/State/Zip: _____
Telephone Number: (_____) _____
E-Mail Address: _____
Original Date of Purchase: ____/____/____
Product Model #: _____
Serial # (if applicable): _____



BRATWURST

2 ½ lb lean veal 2 ½ lb lean pork 1 ½ cup water
 2 tsp dried sage 3 tsp salt
 1 tsp ground white pepper 1 cup fine bread crumbs -soaked in ½ cup milk

- Grind the veal and pork through the coarse grinder plate using the grinding instructions
- Add the sage, pepper and salt to the meat and mix well
- After regrinding, using your hands, mix the meat with the bread crumbs
- Add the water, then beat the mixture with a wooden spoon until it is light and fluffy
- Stuff the sausage into casings to make 4" (10 cm) links *See stuffing instructions*

TRADITIONAL GRILLED BURGER PATTIES

1 ½ lb ground beef ¼ cup chopped onion 1 tsp salt
 1 tsp Worcestershire sauce ¼ cup evaporated milk 1 tsp ground pepper

- Preheat grill
- Combine all the ingredients
- Shape the mixture into patties about 3/4" (1.9 cm) thick
- Grill 4" (10 cm) from heat, turning once 10-15 minutes, or until done

BBQ BEEF PATTIES

1 ½ lb ground beef ½ cup chili sauce 2 tsp brown sugar
 ½ cup chopped onion 1 tsp salt 1 tsp lemon juice
 1/3 cup ketchup

- Combine the ground beef, onion and salt
- Shape the mixture into patties about 3/4" (1.9 cm) thick
- Brown in a large covered skillet over medium-high heat, turning once for 10-15 minutes
- Mix ketchup, chili sauce, brown sugar and lemon juice together
- Pour sauce over the patties
- Cover and simmer for 15 minutes, basting occasionally

BAVARIAN PATTIES WITH SAUERKRAUT

1 ½ lb ground beef 1 egg ½ cup applesauce
 1 tsp salt 1/3 cup dry bread crumbs ½ tsp allspice
 ¼ cup chopped onion 16 oz sauerkraut

- Combine the ground beef, egg, applesauce, salt, bread crumbs, allspice and onion
- Shape the mixture into patties about 3/4" (1.9 cm) thick
- Brown in a large skillet over medium heat, turning once, then drain
- Spoon sauerkraut over the patties
- Cover and simmer for 15 minutes

BAYOU BURGERS

1 lb ground beef ½ tsp garlic powder ½ tsp dried thyme
 ¼ cup sliced green onion ¾ tsp crushed dried basil 1 tsp seasoned salt
 ½ tsp hot pepper sauce

- Preheat grill
- Combine all the ingredients
- Shape the mixture into 4 patties about 3/4" (1.9 cm) thick
- Grill 4" (10 cm) from heat, turning once 10-15 minutes, or until done

COMPONENT LIST

PART DESCRIPTION	GRINDER #8	GRINDER #10	GRINDER #22	GRINDER #32
	36-0801-W	36-1001-W	36-2201-W	36-3201-W
1 Front Ring Nut	36-0802	36-1002	36-2202	36-3202
2 Knife	29-0850	29-1250	29-2250	29-3250
3 Auger Pin	36-0804	36-1004	36-2204	36-3204
4 Auger	36-0805	36-1005	36-2205	36-3205
5 Grinder Body	36-0806	36-1006	36-2206	36-3206
6 Protector Pad	36-0807	36-1007	N/A	N/A
7 Clamp Screw	36-0808	36-1008	N/A	N/A
8 Handle	36-0809	36-1009	36-2209	36-3209
9 Thumbscrew	36-0810	36-1010	36-2210	36-3210
11 3/16" (4.5mm) Plate	15-0804	15-1004	15-2204	15-3204
12 3/8" (10mm) Plate	15-0810	15-1010	15-2210	15-3210
13 3 Stuffing Funnels	36-0817	36-1017	36-2217	36-3217
14 Funnel Flange				
15 Stuffing Star				
16 Auger Bearing	36-0811	36-1011	36-2211	36-3211

If any components of this unit are broken or the unit does not operate properly, call Weston Products LLC Toll Free at

1-800-814-4895

Monday thru Friday 8:00am-5:00pm EST. Outside the U.S. call 440-638-3131

ADDITIONAL ACCESSORIES SOLD SEPARATELY

PART DESCRIPTION	MODEL NUMBER
Food Grade Silicone Spray	03-0101-W
Non-stick Burger EXPress Patty Maker	07-0310-W
The Original Jerky Gun Jr.	37-0201-W
Mandoline Vegetable Slicer	01-0006

These products and many more products can be ordered by visiting

WestonSupply.com or by calling

Weston Products LLC Toll Free at 1-800-814-4895

Monday thru Friday 8:00am-5:00pm EST. Outside the U.S. call 440-638-3131

GENERAL SAFETY RULES



READ AND FULLY UNDERSTAND ALL INSTRUCTIONS AND WARNINGS PRIOR TO USING THIS UNIT. YOUR SAFETY IS MOST IMPORTANT! FAILURE TO COMPLY WITH PROCEDURES AND SAFE GUARDS MAY RESULT IN SERIOUS INJURY OR PROPERTY DAMAGE. REMEMBER: YOUR PERSONAL SAFETY IS YOUR RESPONSIBILITY!

- KEEP FINGERS CLEAR of the **Auger** and **Plate** at all times. NEVER reach into any **Grinder** inlet.
- KEEP CHILDREN AWAY. NEVER LEAVE THE **GRINDER** UNATTENDED.
- CHECK FOR DAMAGED PARTS. Before using the **Grinder**, check that all parts are operating properly, and perform the intended functions. Check for alignment of moving parts, binding of moving parts, mounting and any other conditions that may affect the operation.
- If the **Grinder** becomes jammed, briefly turn in reverse to clear blockage.
- NEVER insert fingers or foreign objects into **Grinder** opening.
- TIE BACK loose hair and clothing, and roll up long sleeves before operating the **Grinder**. REMOVE ties, rings, watches, bracelets, or other jewelry before operating the **Grinder**.
- WEAR EYE PROTECTION. Wear safety glasses. Everyday eye glasses are not safety glasses. Safety glasses conform to ANSI Z87.1 requirements. Note: approved safety glasses have Z87 printed or stamped on them.
- Trim meat of all clots, cords, tendons, bones, etc. before grinding.
- DO NOT grind bones, nuts or other hard objects.
- DO NOT use the **Grinder** while under the influence of drugs or alcohol.

SAVE THESE INSTRUCTIONS!

Refer to them often and use them to instruct others.

CLEANING INSTRUCTIONS

- PROPERLY CLEAN THE GRINDER PRIOR INITIAL USE!
- Disassemble the **Grinder** and hand wash each part thoroughly in warm, soapy water taking particular care to remove all grease and oil from the surfaces.
- Dry all parts thoroughly before re-assembling. DO NOT ALLOW parts to air-dry.
- Coat all metal parts, including the **Plates** and **Knife**, with a food-grade silicone spray to prevent corrosion.
- The **Grinder** is NOT dishwasher safe.

SPECIAL NOTE FOR #32 GRINDERS ONLY: If the **Front Ring Nut** is difficult to remove the **Handle** is designed with a small hole drilled into the back, which allows it to be used as a wrench to remove the **Front Ring Nut** only. DO NOT use this feature to tighten the **Front Ring Nut**.

RECIPES

U.S. WEIGHT CONVERSIONS	
1 oz	28 g
1/4 lb or 4 oz	113 g
1/3 lb	150 g
1/2 lb or 8 oz	230 g
2/3 lb	300 g
3/4 lb or 12 oz	340 g
1 lb or 16 oz	450 g
2 lb	900 g

U.S. VOLUME CONVERSIONS	
1 tsp	5 ml
1 Tbsp	15 ml
1/8 cup or 1 fl oz	30 ml
1/4 cup or 2 fl oz	60 ml
1/3 cup	80 ml
1/2 cup or 4 fl oz	120 ml
2/3 cup	160 ml
3/4 cup or 6 fl oz	180 ml
1 cup or 8 fl oz or 1/2 pint	240 ml
1 1/2 cup or 12 fl oz	350 ml
2 cups or 16 fl oz or 1 pint	475 ml
3 cups or 1 1/2 pints	700 ml
4 cups or 2 pints or 1 qt	950 ml
4 quarts or 1 gal	3.8 L

VENISON SAUSAGE

- | | |
|------------------------|----------------------------|
| 6 lb venison | 6 lb lean pork |
| 1/2 tsp sage | 2 tsp salt |
| 1/2 tsp cayenne pepper | 1/2 cup honey |
| 2 tsp pepper | Sausage Casings (optional) |

- Grind the venison and pork through the coarse grinder plate using the grinding instructions
- Add all the ingredients to the meat and mix well
- Regrind the mixed meat through the fine grinding plate using the grinding instructions
- Stuff the sausage into casings or shape into patties *See stuffing instructions*

VENISON BREAKFAST SAUSAGE PATTIES

- | | | |
|---------------|--------------|--------------|
| 6 lbs venison | 1/2 lb bacon | 1 tsp pepper |
| 1/2 tsp sage | 1 tsp salt | |

- Grind the venison and bacon through the fine grinder plate using the grinding instructions
- Add all the ingredients to the meat and mix well
- Refrigerate the mixture for a few hours before use
- Shape the mixture into thin patties
- Pour a little oil into a skillet or onto a griddle and heat to medium high
- Grill the patties for a few minutes on each side

VENISON SUMMER SAUSAGE - SPICY

- | | | |
|---|------------------------------|---------------|
| 15 lb venison | 1/4 cup mustard seeds | 1 cup pepper |
| 10 lb pork trimmings (1/2 lean - 1/2 fat) | 2/3 cup salt | 1/2 cup sugar |
| 3 tsp marjoram | 4 level tsp Prague Powder #1 | |

- Grind the venison and pork through the coarse grinder plate using the grinding instructions
- Mix salt and cure with the venison and pork grindings
- Pack into a shallow pan and place in refrigerator for 3-5 days
- Add the rest of the ingredients and mix well
- Pour a little oil into a skillet or onto a griddle and heat to medium high
- Grill the patties for a few minutes on each side

CHORIZO (MEXICAN) SAUSAGE

- | | | |
|--|-------------------------|--------------------------|
| 2 lb lean pork trimming | 2 medium onions, minced | 8 cloves garlic, pressed |
| 1/2 cup cider vinegar | 1 Tbsp ground oregano | 8 oz beef or pork fat |
| 1/4 cup ground red chili (mild or hot) | 1 tsp ground cinnamon | Sausage casings |

- Grind the meat and fat through the coarse grinder plate using the grinding instructions
- Add the onions, garlic, vinegar and seasonings (use chili to taste)
- Mix the ground meat and the seasonings, then place in a covered bowl and refrigerate for at least one hour
- Stuff the sausage into casings to make 4" (10.2 cm) links *See stuffing instructions*

must all be carefully monitored for a safe and delicious product.

STORAGE

It is important to remember that sausage will lose its flavor the longer that it is stored. It is recommended that you only make as much sausage as you will need for 4-6 weeks. Even frozen sausage will begin to lose flavor noticeably after 6 weeks. Frozen sausage should be thawed slowly in the refrigerator before cooking or serving. Quick thawing of the product will degrade the taste as well.

FOOD SAFETY

There are basic rules to follow when handling food. They are **COOK, SEPARATE, CLEAN,** and **CHILL.**

COOK

It's crucial to cook food to a safe internal temperature to destroy bacteria that is present. The safety of hamburgers and other foods made with ground meat has been receiving a lot of attention lately, and with good reason. When meat is ground, the bacteria present on the surface is mixed throughout the ground mixture. If this ground meat is not cooked to at least 160°F to 165°F (71°C to 74°C), bacteria will not be destroyed and there's a good chance you will get sick.

Solid pieces of meat like steaks and chops don't have dangerous bacteria like E. coli on the inside, so they can be served more rare. Still, any beef cut should be cooked to an internal temperature of at least 145°F (63°C) (medium rare). The safe temperature for poultry is 180°F (82°C) and solid cuts of pork should be cooked to 160°F (71°C). Eggs should be thoroughly cooked too. If you are making a meringue or other recipe that uses uncooked eggs, buy specially pasteurized eggs or use prepared meringue powder.

SEPARATE

Foods that will be eaten uncooked and foods that will be cooked before eating **MUST ALWAYS** be separated. Cross-contamination occurs when raw meats or eggs come in contact with foods that will be eaten uncooked. This is a major source of food poisoning. Always double-wrap raw meats and place them on the lowest shelf in the refrigerator so there is no way juices can drip onto fresh produce. Then use the raw meats within 1-2 days of purchase, or freeze for longer storage. Defrost frozen meats in the refrigerator, not on the counter.

When grilling or cooking raw meats or fish, make sure to place the cooked meat on a clean platter. Don't use the same platter you used to carry the food out to the grill. Wash the utensils used in grilling after the food is turned for the last time on the grill, as well as spatulas and spoons used for stir-frying or turning meat as it cooks.

Make sure to wash your hands after handling raw meats or raw eggs. Washing hands with soap and water, or using a pre-moistened antibacterial towelette is absolutely necessary after you have touched raw meat or raw eggs. Not washing hands and surfaces while cooking is a major cause of cross-contamination.

CLEAN

Wash your hands and work surfaces frequently when you are cooking. Washing with soap and warm water for at least 15 seconds, then dry with a paper towel.

CHILL

Chilling food is very important. The danger zone where bacteria multiply is between 40°F and 140°F (4°C and 6°C). Your refrigerator should be set to 40°F (4°C) or below; your freezer should be 0°F (-17°C) or below. Simple rule: serve hot foods hot, cold foods cold. Use chafing dishes or hot plates to keep food hot while serving. Use ice water baths to keep cold foods cold. Never let any food sit at room temperature for more than 2 hours - 1 hour if the ambient temperature is 90°F (32°C) or above. When packing for a picnic, make sure the foods are already chilled when they go into the insulated hamper. The hamper won't chill food - it just keeps food cold when properly packed with ice. Hot cooked foods should be placed in shallow containers and immediately refrigerated so they cool rapidly. Make sure to cover foods after they are cool.

NOTE: Special considerations must be made when using venison or other wild game, since it can become heavily contaminated during field dressing. Venison is often held at temperatures that could potentially allow bacteria to grow, such as when it is being transported. Refer to the USDA Meat and Poultry Department for further questions or information on meat and food safety.

GRINDER ASSEMBLY

1. A. If you are using a clamp down, **#8** or **#10 Grinder**, slide the **Protector Pad** onto the foot of the **Grinder** and tighten the **Clamp Screw** to secure the **Grinder** to the work surface. Allow ample room for the **Handle** to rotate.

B. If you are using a bolt down **#22** or **#32 Grinder**, the body of the **Grinder** can be attached to a solid work surface using appropriately sized screws. Allow ample room for the **Handle** to rotate.

2. Insert the **Auger Bearing** into the **Grinder Body** through the hole in the back of the **Grinder**. **FIGURE 1**

3. Insert the **Auger** into the **Grinder Body**, rotate the **Auger** while inserting to fully seat the **Auger** into the **Grinder Body**.

4. Slide the **Knife** over the square portion of the **Auger Pin** on the front of the **Auger** making sure the cutting edges of the **Knife** are facing outward.

5. Slide the **Plate** of choice over the round portion of the **Auger Pin**. Align the notch on the **Plate** with the notch in the **Grinder Body** so that the **Plate** fully sits in the opening of the **Grinder Body**.

6. Snugly screw on the **Front Ring Nut**. **DO NOT OVER TIGHTEN!** (If the **Front Ring Nut** is screwed onto the **Grinder Body** too tightly, the **Auger** will be hard to turn/will not turn. The **Front Ring Nut** should be snug, allowing the **Auger** to spin with ease.)

7. Slide the **Handle** over the exposed end of the **Auger** and lock it in place with the **Thumbscrew**. **FIGURE 2**

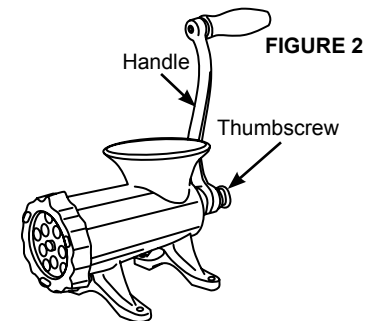
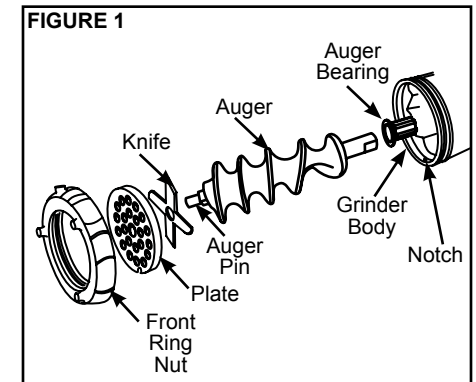

GRINDING INSTRUCTIONS

• Trim meat of all blood clots, cords, tendons, bones, etc. **NEVER** grind bones, nuts or other hard objects.

• For best results, be sure that all meat has been chilled to between 32-34°F (0-1°C) before grinding. **DO NOT** allow meat to sit out at room temperature longer than is absolutely necessary. *Follow the Food Safety Guidelines as outlined.*

• Cut meat into sizes small enough to fit into the **Grinder**. Approximately 1" (2.5 cm) cubes.

• As you feed chunks of meat into the **Grinder** turn the **Handle** clockwise (when facing the **Handle** side of the **Grinder**). Be sure to have something to catch the meat as it comes out of the **Grinder**.

• If for some reason the **Grinder** should get stuck or become hard to turn; turn the **Handle** counter-clockwise to loosen the obstruction, then resume grinding. If this doesn't free the back-up, remove the **Front Ring Nut, Plate, Knife** and **Auger** to remove the obstruction.

STUFFER ASSEMBLY

1. A. If you are using a clamp down, **#8 or #10 Grinder**, slide the **Protector Pad** onto the foot of the **Grinder** and tighten the **Clamp Screw** to secure the **Grinder** to the work surface. Allow ample room for the **Handle** to rotate.

B. If you are using a bolt down **#22 or #32 Grinder**, the body of the **Grinder** can be attached to a solid work surface using appropriately sized screws. Allow ample room for the **Handle** to rotate.

2. Insert the **Auger Bearing** into the **Grinder Body** through the hole in the back of the **Grinder**. *FIGURE 3*

3. Insert the **Auger** into the **Grinder Body**, rotate the **Auger** while inserting to fully seat the **Auger** into the **Grinder Body**.

4. Slide the **Stuffing Star** over the round portion of the **Auger Pin**.

5. Attach the **Stuffing Flange** to the **Funnel** that will be used. Slide the **Stuffing Funnel** through the **Front Ring Nut**.

6. Snugly screw on the **Front Ring Nut**. **DO NOT OVER TIGHTEN!** (If the **Front Ring Nut** is screwed onto the **Grinder Body** too tightly, the **Auger** will be hard to turn/will not turn. The **Front Ring Nut** should be snug, allowing the **Auger** to spin with ease.)

7. Slide the **Handle** over the exposed end of the **Auger** and lock it in place with the **Thumbscrew**. *FIGURE 4*

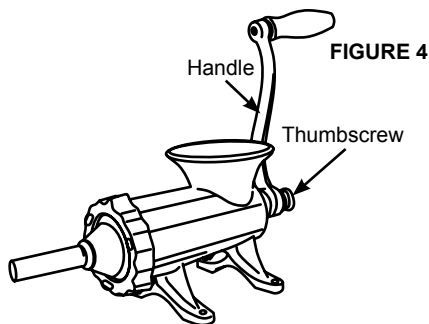
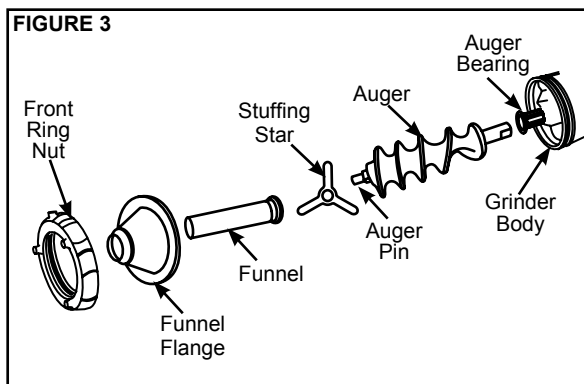

STUFFER ASSEMBLY

- For the best stuffing results, two people are recommended for this operation.
- Fill the **Grinder** hopper with pre-ground, seasoned meat.
- Slide a sausage casing over the end of the **Stuffing Funnel**, leaving 4-6" (10.2-15.2 cm) of casing off the end of the **Stuffing Funnel**. Tie a knot in the end of the casing.
- While holding the casing on the **Stuffing Funnel** with one hand, rotate the **Handle** clockwise (when facing the **Handle** side of the **Grinder**) to move the meat through the **Grinder** and into the casing. Gently lay the filled casing on a plate as the casing fills.
- Do not fill the last 3-4" (7.6-10.2 cm) of the casing. When finished stuffing, twist and tie the end closed.

SAUSAGE INFORMATION

MEAT SELECTION FOR SAUSAGE MAKING

Sausage making has evolved over many years and generations, and as a result there are countless types of sausage you can make using the basic ingredients of meat, fat and a few carefully blended spices. Following are a few simple guidelines that will help you make the best tasting sausage possible.

Any type of meat can be used for making sausage: pork, beef, bison, moose and caribou, even antelope make great sausage. It is important when preparing venison or other red game meats to trim all the fat from the meat, as red game tallow will turn rancid in as few as five days. Replace the fat with either pork or beef fat, depending on the type of product you are making, at a ratio of 1 pound (0.5 kg) of fat for every 4 pounds (1.8 kg) of game meat.

The fat content of your sausage will affect the taste, texture, cooking characteristics and shelf life of your product. Most commercially made sausage has a fat content of about 20%. Using less than 12% fat will result in a very dry tasting sausage, while using more than 20% may result in a sticky flavorless sausage that will be difficult to cook.

CURING

It is important to properly cure meats to preserve meat and poultry, and to destroy undesirable microorganisms on the meat surfaces that cause spoilage and food born illnesses. There are many steps that help in this process, including smoking, cooking, drying, chilling and the addition of cure ingredients. The oldest means of accomplishing this is by introducing salt into the meat. The resistance of bacteria to salt varies widely among different types of bacteria. The growth of some bacteria is inhibited by salt concentrations as low as 3%, e.g., Salmonella, whereas other types are able to survive in much higher salt concentrations, e.g., Staphylococcus. Fortunately, the growth of many undesirable organisms normally found in cured meat and poultry products is inhibited at low concentrations of salt.

Modern curing is based on Nitrates and is very scientific. The best way to ensure proper curing is to purchase one of the many commercially available curing agents from either a grocery store or your local butcher. A very common cure is Prague Powder, which is available in two types (#1 and #2).

CASING

There are many different types of casings available, the right choice depends on personal preference as well as the type of sausage you wish to make. For most sausages, your choices are natural or collagen. Don't let the names fool you; collagen casings are not a synthetic product. They are made from beef skin and other tissues. Collagen casings are uniform in size and texture and require almost no preparation. "Natural" casings are the intestines of lamb, sheep, hogs or beef. They are less uniform in size and require substantial preparation. For those reasons, more than 75% of commercially made sausage in the U.S. is made with collagen casing. There are also fibrous non-edible casings that are used for some varieties of smoked sausages and bolognas.

TYPES OF SAUSAGE

Most sausages fall into one of four categories: Fresh, Smoked, Cooked or Dried. All sausages, except dried, require refrigerated storage. There is also a sub-category of uncooked smoked sausages.

Among the fresh and uncooked smoked sausages, you will find such flavors as kielbasa or Polish sausage, Italian sausage, breakfast sausage and many others. Both fresh and uncooked smoked sausages require cooking before eating and also require refrigerated storage.

Smoked and cooked sausages include salami, bologna, the ever-popular hot dogs and many others. Proper smoking requires a smokehouse or smoker. These can be simple home-built structures made from metal drums or even old refrigerators or they can be elaborate manufactured units. Most smoked sausages are warmed before serving. Many people think that a smoked sausage will last much longer without spoilage, but this is not true. Smoked sausages should be treated the same as fresh sausage in terms of storage.

Dried sausages require the longest processing time, as they are air dried over a long period of time. Some types of dry sausages are pepperoni, prosciutto and a variety of ham products, just to name a few. The conditions under which the meat is dried are very exacting; temperature, time and humidity