



ATTENTION

If any components of this unit are broken,
do not operate properly, or for product returns,
please contact PragoTrade LLC at

1-800-814-4895

Outside the U.S. call 440-638-3131.

For the online catalog, log onto www.westonsupply.com.

Exclusively imported by PragoTrade LLC Strongsville, Ohio
www.pragotrade.com

WESTON

SINGLE SUPPORT MANUAL MEAT CUBER/TENDERIZER & JERKY SLICER INSTRUCTIONS



Meat Cuber/
Tenderizer
Model No.
07-4101-W-A

Jerky Slicer
Model No.
07-3801-W-A

WARRANTY INFORMATION

SAVE THIS WARRANTY INFORMATION FOR YOUR RECORDS!

Pragotrade LLC warrants to the ORIGINAL RETAIL PURCHASER of this product that if operated in accordance with the printed instruction accompanying it, then for a period of 1 year from the date of purchase, the product shall be free from defects in material and workmanship.

The Warranty Card, along with a copy of the original receipt, must be received by Pragotrade LLC within 30 days from purchase date for the warranty to apply. Failure to send the completely filled out Warranty Card, along with a copy of the original receipt, will void the warranty.

The product must be delivered to or shipped freight prepaid to Pragotrade LLC for warranty services, in either its original packaging or similar packaging affording an equal degree of protection. Damage due to shipping is not the responsibility of the company. Pragotrade LLC charges a \$35.00 per hour bench charge. NOTE: No repairs will be started without the authorization of the customer. The return shipping cost to the customer will be added to the repair invoice.

Pragotrade LLC will repair (or at its discretion, replace) the product free of charge, if in the judgment of the company, it has been proven to be defective as to seller's labor and material, within the warranty period.

New or rebuilt replacements for factory defective parts will be supplied for one (1) year from the date of purchase. Replacement parts are warranted for the remainder of the original warranty period.

For non-warranty repairs, contact Pragotrade's Customer Service at 1-800-814-4895 M-F 8am-5pm EST (outside of the United States 440-638-3131) to obtain a Return Authorization Number (RMA Number). Pragotrade will refuse all returns that do not contain this number. **DO NOT RETURN THE UNIT WITHOUT PROPER AUTHORIZATION FROM PRAGOTRADE LLC.**

LIMITATIONS: The warranty is void if the product is used for any purpose other than that for which it is designed. The product must not have been previously altered, repaired, or serviced by anyone else other than Pragotrade LLC. If applicable, the serial number must not have been altered or removed. The product must not have been subjected to accident in transit or while in the customer's possession, misused, abused, or operated contrary to the instructions contained in the instruction manual. This includes failure caused by neglect of reasonable and necessary maintenance, improper line voltage and acts of nature. This warranty is not transferable and applies only to U.S. and Canadian sales.

Except to the extent prohibited by applicable law, no other warranties whether expressed or implied, including warranty merchantability and fitness for a particular purpose, shall apply to this product. Under no circumstances shall Pragotrade LLC be liable for consequential damages sustained in connection with said product and Pragotrade LLC neither assumes nor authorizes any representative or other person to assume for it any obligation or liability other than such as is expressly set forth herein. Any applicable implied warranties are also limited to the one (1) year period of the limited warranty.

This warranty covers only the product and its specific parts, not the food or other products processed in it.

CUT ALONG THE DOTTED LINE AND SEND THE WARRANTY CARD ALONG WITH A COPY OF YOUR ORIGINAL PURCHASE RECEIPT TO:

Pragotrade LLC
20365 Progress Drive, Strongsville, OH 44149

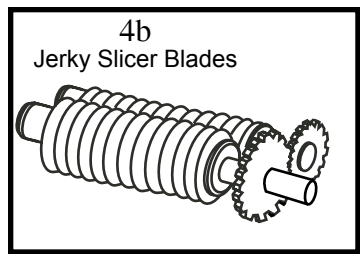
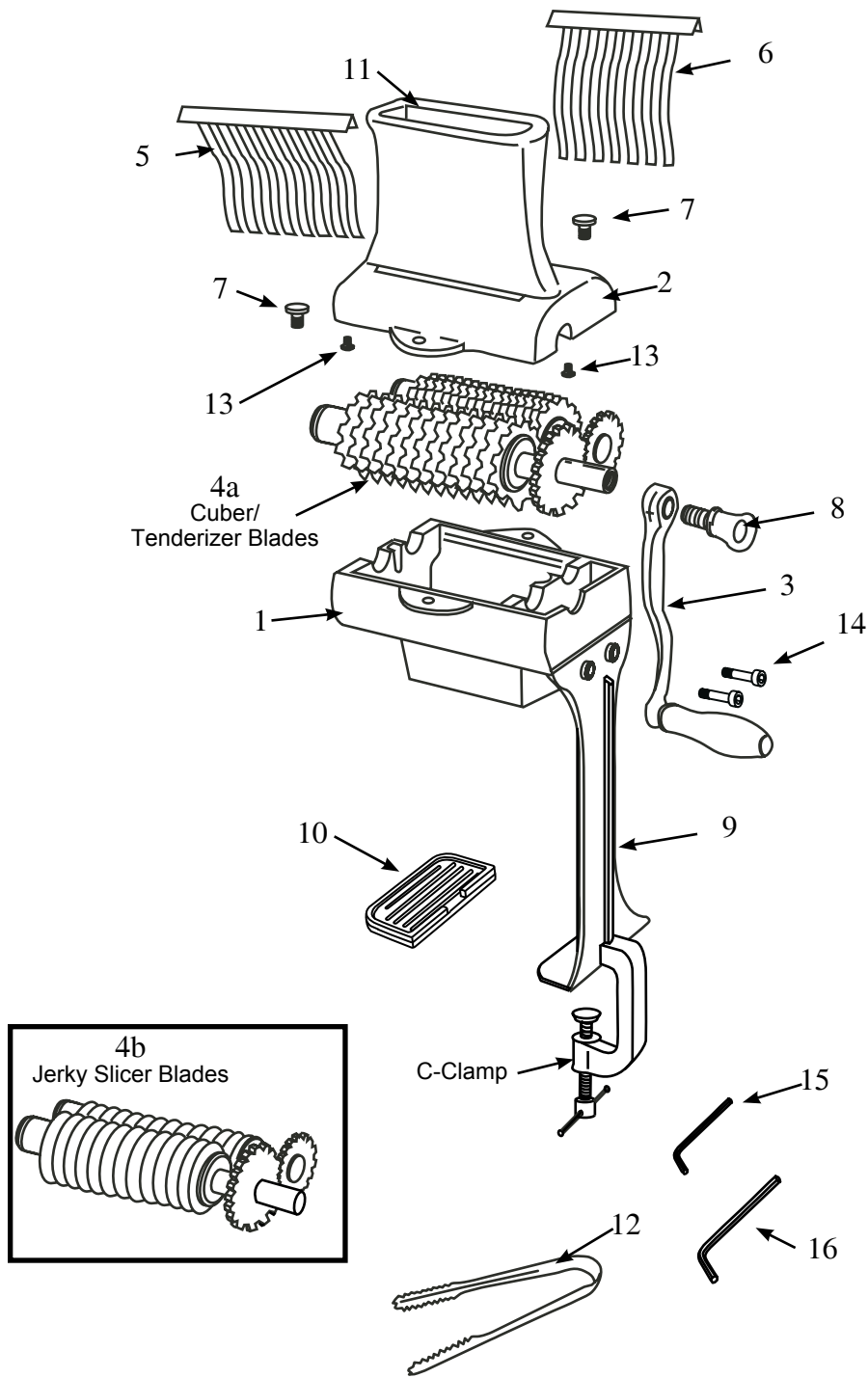

WARRANTY CARD

SEND THIS CARD ALONG WITH A COPY OF YOUR ORIGINAL PURCHASE RECEIPT

Customer Name: _____

Address: _____

City/State/Zip: _____

Telephone Number: (____) _____

E-Mail Address: _____

Original Date of Purchase: ____/____/____

Product Model #: _____

Serial # (if applicable): _____

Blackened Cajun Rub

1 1/2 <i>tblsp paprika</i>	1 <i>tblsp garlic powder</i>
1 <i>tblsp onion powder</i>	1 <i>tblsp ground dried thyme</i>
1 <i>tsp ground black pepper</i>	1 <i>tsp cayenne pepper</i>
1 <i>tsp dried basil</i>	1 <i>tsp dried oregano</i>

DIRECTIONS

- Combine paprika, garlic powder, onion powder, thyme, black pepper, cayenne pepper, basil, and oregano in a bowl until evenly mixed.
- Rub mixture onto meat before cooking.
- Store excess rub mixture in an airtight container in a cool, dry place.

Sweet & Sour BBQ Marinade

1 <i>tblsp olive oil</i>	1 <i>small onion, chopped</i>
1/2 <i>red bell pepper</i>	1/4 <i>cup brown sugar</i>
1 <i>tsp garlic</i>	1 <i>tblsp dry mustard</i>
1/2 <i>cup cider vinegar</i>	4 <i>cups pineapple juice</i>
1 (16 ounce) <i>jar pineapple fruit preserves</i>	

DIRECTIONS

- Brown onions and red peppers in olive oil.
- Add brown sugar, garlic, mustard, and cider vinegar.
- Cook for one minute on high or until bubbly.
- Add pineapple juice.
- Coat meat with marinade and marinate meat overnight in a covered dish in the refrigerator.
- Remove meat from marinade and grill or cook as desired.
- Near the end of the cooking, add preserves to top and allow to brown slightly.

Steak Marinade

1/3 <i>cup sherry</i>	1/3 <i>cup soy sauce</i>
1/3 <i>cup vegetable oil</i>	2 <i>tblsp honey</i>
2 <i>tblsp grated fresh ginger root</i>	1 <i>clove garlic, minced</i>

DIRECTIONS

- In a medium bowl, mix sherry, soy sauce, vegetable oil, honey, ginger and garlic.
- Coat meat with marinade and marinate meat for 4 hours in a covered dish in the refrigerator.

Fajitas

1/4 <i>cup vegetable oil</i>	1/4 <i>cup lemon juice</i>
3 <i>garlic cloves, minced</i>	1 1/2 <i>tsp grated lemon peel</i>
1/4 <i>tsp chili powder</i>	1/4 <i>tsp pepper</i>
3/4 <i>lb sliced steak or chicken</i>	3 <i>green onions, thinly sliced</i>
4 (8") <i>flour tortillas</i>	

DIRECTIONS

- In a bowl, combine the oil, lemon juice, garlic, lemon peel, chili powder and pepper.
- Place half in a re-sealable plastic bag; cover and refrigerate remaining marinade.
- Add meat to bag. Seal and turn to coat; refrigerate for 4-8 hours.
- Drain and discard marinade. In a skillet, heat reserved marinade.
- Add meat and green onions.
- Cook and stir until meat reaches desired doneness.
- Using a slotted spoon, place about 1/2 cup meat mixture down the center of each tortilla.
- Top with optional ingredients- salsa, cheese, sour cream, guacamole, lettuce.

COMPONENT LIST

DIAGRAM NUMBER	PART DESCRIPTION	MODEL NO. 07-4101-W-A	MODEL NO. 07-3801-W-A
1	Bottom Housing	07-4110-A	07-3808-A
2	Top Housing	07-3181-A	07-3307-A
3	Handle	07-3125-A	07-3502-A
4a	Cuber/Tenderizer Blade Assembly	07-3103	<i>Not Included</i>
4b	Jerky Slicer Blade Assembly	<i>Not Included</i>	07-3302
5	Left Comb	07-3306	07-3306
6	Right Comb	07-3305	07-3305
7	Housing Thumbscrew (2)	07-3166	07-3166
8	Handle Thumbscrew	07-3505	07-3505
9	Support Leg	07-4103	07-3811
10	Countertop Protector Pad	07-4104	07-4104
11	Chute	07-3182-A	07-3812-A
12	Stainless Steel Tongs	07-3151	07-3151
13	Chute Screw (2)	07-3183	07-3183
14	Support Leg Screw (2)	07-4105	07-4105
15	Small Allen Wrench <i>for Chute Screws</i>	07-3178	07-3178
16	Large Allen Wrench <i>for Support Leg Screws</i>	07-4109	07-4109

If any components of this unit are broken or the unit does not operate properly, call PragoTrade LLC Toll Free at

1-800-814-4895

Monday thru Friday 8:00am-5:00pm EST.
Outside the U.S. call 440-638-3131

ADDITIONAL ACCESSORIES AVAILABLE

ACCESSORY DESCRIPTION	MODEL NO.
Cuber/Tenderizer Blade Assembly*	07-3103
Jerky Slicer Blade Assembly*	07-3302
*Transform the Cuber/Tenderizer into a Jerky Slicer (or the Jerky Slicer into a Cuber/Tenderizer) by replacing the Blade Assembly .	
VegiKILN 10 Tray Food Dehydrator System	75-0201-W
3-Tier Oven Drying Rack	07-0155-W

These products and many more products can be ordered by visiting

www.westonsupply.com or by calling

PragoTrade LLC Toll Free at 1-800-814-4895

Monday thru Friday 8:00am-5:00pm EST.
Outside the U.S. call 440-638-3131

GENERAL SAFETY RULES



READ AND FULLY UNDERSTAND ALL INSTRUCTIONS AND WARNINGS PRIOR TO USING THIS PRODUCT. YOUR SAFETY IS MOST IMPORTANT! FAILURE TO COMPLY WITH PROCEDURES AND SAFEGUARDS MAY RESULT IN SERIOUS INJURY OR PROPERTY DAMAGE. **REMEMBER: YOUR PERSONAL SAFETY IS YOUR RESPONSIBILITY!**

1. CAUTION SHARP BLADES!

Wear Kevlar, cut-resistant gloves (*Sold Separately*) when handling the **Blades**.

2. **NEVER REACH INTO** the **Cuber/Tenderizer** or the **Jerky Slicer**. Doing so could cause serious injury. **ALWAYS USE THE PROVIDED TONGS.**

3. **KEEP FINGERS CLEAR OF THE BLADES AT ALL TIMES.** Failure to do so may result in personal injury. The **Cutting Blades/Blade Assembly** is very sharp. Wear Kevlar, cut-resistant gloves (*Sold Separately*) when handling the **Blades**.

4. **DO NOT** press or push meat into the **Chute** with your fingers or any other object. Doing so may cause personal injury and/or damage to the unit.

5. **NEVER** use fingers to scrape food away from the **Cuber/Tenderizer** or the **Jerky Slicer** while in operation. **SEVERE INJURY MAY RESULT.**

6. **DO NOT** push the **Tongs** or other utensils into the **Blades**.

7. **NEVER LEAVE THE Cuber/**

Tenderizer or the **Jerky Slicer UNATTENDED.** Close supervision is necessary when any appliance is used near children. This appliance is **NOT** to be used by children.

8. **NEVER** use any accessories or parts from other manufacturers. Doing so will **VOID YOUR WARRANTY.**

9. Thoroughly clean all parts that will come into contact with food before using the **Cuber/Tenderizer** or the **Jerky Slicer**. Wash all parts by hand and dry thoroughly. Wear Kevlar, cut-resistant gloves (*Sold Separately*) when handling the **Blades**.

10. **DO NOT** attempt to tenderize or slice meat with bones or other hard items. Damage to the machine will occur.

11. **TIE BACK** loose hair and clothing, and roll up long sleeves before operating the **Cuber/Tenderizer** or the **Jerky Slicer**. **REMOVE** ties, rings, watches, bracelets, or other jewelry before operating.

12. **DO NOT** use the **Cuber/Tenderizer** or the **Jerky Slicer** while under the influence of drugs, medications or alcohol.

SAVE THESE INSTRUCTIONS!

Refer to them often and use them to instruct others.

CLEANING INSTRUCTIONS

1. Thoroughly wash all parts in soapy water. Rinse with clean water. Dry all parts immediately. **NOTE: DO NOT** immerse the **Blade Assembly** in sudsy water where they cannot be seen. To prevent injury, keep the **Blade Assembly** visible at all times. **CAUTION: The Blades are very sharp!**

2. Coat all metal parts with a food grade silicone spray.

HELPFUL HINT: A long, skinny brush is helpful when cleaning the **Blade Racks**.



RECIPES

Citrus Spice Mojo Marinade

6 cloves garlic, coarsely chopped
1 cup freshly squeezed orange juice
1/2 tsp ground cumin
1/2 tsp lemon-pepper seasoning
1 tsp kosher salt
1 tsp hot pepper sauce

1/2 cup minced yellow onion
1/2 cup freshly squeezed lime juice
1 tsp dried oregano flakes
1/2 tsp freshly ground black pepper
1/4 cup chopped cilantro
1 cup olive oil

DIRECTIONS

- Pulse the garlic and onion in a blender until very finely chopped.
- Pour in orange juice, lime juice; season with cumin, oregano, lemon-pepper, black pepper, salt, cilantro, and hot pepper sauce.
- Blend until thoroughly incorporated.
- Pour in the olive oil, and blend until smooth.
- Coat meat with marinade and marinate meat for 1 hour in a covered dish in the refrigerator.
- Remove meat from marinade and grill or cook as desired.

5 Star Jerky Marinade

1/2 cup soy sauce
1/2 tsp liquid smoke flavoring
1 tsp garlic powder
1/2 tsp black pepper

1/4 cup Worcestershire sauce
1 tsp hot pepper sauce, or to taste
1 tsp onion powder
1/2 cup brown sugar

DIRECTIONS

- Stir together soy sauce, Worcestershire sauce, liquid smoke, and hot pepper sauce in a bowl.
- Season with garlic powder, onion powder, pepper, and sugar; stir until mixed.
- Coat meat with marinade and marinate meat for 48 hours in a covered dish in the refrigerator.
- Remove meat from marinade, and discard excess marinade.
- Prepare jerky according to the manufacturer's directions of your smoker or dehydrator.

Teriyaki Marinade

1/3 cup water
1/3 cup soy sauce
1/2 tsp ground cinnamon

1/3 cup brown sugar
1 tsp crushed garlic

DIRECTIONS

- In a medium bowl, mix water, brown sugar, soy sauce, garlic, and cinnamon.
- Coat meat with marinade and marinate meat for 2 hours in a covered dish in the refrigerator.
- Remove meat from marinade and grill or cook as desired.

Ginger, Garlic, Teriyaki Marinade

1/2 cup soy sauce
1/4 cup white wine
1 tbsp fresh ginger root, finely chopped
1/2 tsp crushed red pepper flakes

1/4 cup red wine vinegar
2 tbsp honey
4 cloves garlic, minced

DIRECTIONS

- In a medium bowl, mix soy sauce, red wine vinegar, white wine, honey, fresh ginger root, garlic and crushed red pepper flakes.
- Coat meat with marinade and marinate meat for 2 hours in a covered dish in the refrigerator.
- Remove meat from marinade and grill or cook as desired.

temperature is 90°F (32°C) or above. When packing for a picnic, make sure the foods are already chilled when they go into the insulated hamper. The hamper won't chill food - it just keeps food cold when properly packed with ice. Hot cooked foods should be placed in shallow containers and immediately refrigerated so they cool rapidly. Make sure to cover foods after they are cool.

NOTE: Special considerations must be made when using venison or other wild game, since it can become heavily contaminated during field dressing. Venison is often held at temperatures that could potentially allow bacteria to grow, such as when it is being transported. Refer to the USDA Meat and Poultry Department for further questions or information on meat and food safety.

ASSEMBLY INSTRUCTIONS

1. Remove the **Housing Thumbscrews** securing the **Top Housing** to the **Bottom Housing** (Figure 1).

2. Remove the **Top Housing** and **Blade Assembly** from the **Bottom Housing**.
CAUTION! Blades are very sharp!

3. Using the **Large Allen Wrench** and **Support Leg Screws**, attach the **Support Leg** to the **Lower Housing**.

4. Install the **Chute** to the **Top Housing** using an **Small Allen Wrench** and **Chute Screws**.

5. Attach the **Countertop Protector Pad** to the **Support Leg**.

6. Mount the **Cuber/Tenderizer** or **Jerky Slicer** to a table, workbench or other stable, sturdy structure with the **C-Clamp**.

7. Insert the **Blade Assembly** into the **Lower Housing**, guiding the **Drive Shaft** into the bearing journals. Make sure the teeth of the **Blade Assembly** are properly meshed together.

8. Position the **Top Housing** onto the **Lower Housing** and line up the screw holes.

9. Secure the **Top Housing** to the **Lower Housing** using the **Housing Thumbscrews**. **DO NOT OVERTIGHTEN!**

10. Insert the **Left** and **Right Combs** into the **Top Housing** (Figure 2).

NOTE: The **Combs** and **Top Housing** are marked "L - Left" and "R - Right" to aid **Comb** installation.

11. Install **Handle** onto the **Blade Assembly Shaft**.

12. Secure the **Handle** to **Blade Rack Shaft** with the **Handle Thumbscrew**.

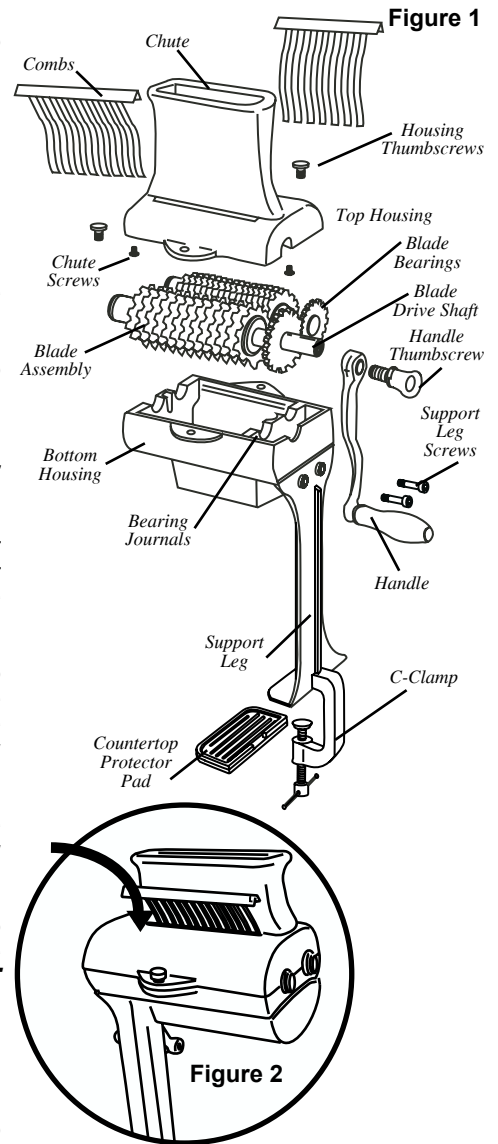

DIRECTIONS FOR USE

1. Make sure the **Support Leg/C-Clamp** is firmly attached to the work surface and the **Handle** can freely rotate.
2. Make sure the **Combs** are properly installed. DO NOT use the **Cuber/Tenderizer** or **Jerky Slicer** without the **Combs** in place.
3. Place a dish under the **Bottom Housing** to catch meat as it exits the **Cuber/Tenderizer** or **Jerky Slicer**.
4. Meat cuts should be 1 1/4" (3.2 cm) thick or less. Cuts of meat that are too thick may damage the **Blades**.
5. Using the **Tongs**, insert meat into the opening at the top of the **Chute** until it contacts the **Blades**.
6. While facing the **Cuber/Tenderizer** or **Jerky Slicer** with the **Handle** to the right, rotate the **Handle CLOCKWISE** to tenderize or slice the meat. The **Blades** will pull meat through the **Cuber/Tenderizer** or **Jerky Slicer**. DO NOT force meat into the **Blades**.

! NEVER REACH INTO the **Cuber/Tenderizer** or the **Jerky Slicer**. Doing so could cause serious injury. **ALWAYS USE THE PROVIDED TONGS.**

! KEEP FINGERS CLEAR OF THE BLADES AT ALL TIMES. Failure to do so may result in personal injury. The **Cutting Blades/Blade Assembly** is very sharp.

! DO NOT press or push meat into the **Chute** with your fingers or any other object. Doing so may cause personal injury and/or damage to the unit.

! NEVER use fingers to scrape food away from the **Cuber/Tenderizer** or the **Jerky Slicer** while in operation. **SEVERE INJURY MAY RESULT.**

! DO NOT push the **Tongs** or other utensils into the **Blades**.



FOOD SAFETY

There are basic rules to follow when handling food. They are **COOK, SEPARATE, CLEAN, and CHILL.**

COOK

It's crucial to cook food to a safe internal temperature to destroy bacteria that is present. The safety of hamburgers and other foods made with ground meat has been receiving a lot of attention lately, and with good reason. When meat is ground, the bacteria present on the surface is mixed throughout the ground mixture. If this ground meat is not cooked to at least 160°F to 165°F (71°C to 74°C), bacteria will not be destroyed and there's a good chance you will get sick.

Solid pieces of meat like steaks and chops don't have dangerous bacteria like E. coli on the inside, so they can be served more rare. Still, any beef cut should be cooked to an internal temperature of at least 145°F (63°C) (medium rare). The safe temperature for poultry is 180°F (82°C) and solid cuts of pork should be cooked to 160°F (71°C). Eggs should be thoroughly cooked too. If you are making a meringue or other recipe that uses uncooked eggs, buy specially pasteurized eggs or use prepared meringue powder.

SEPARATE

Foods that will be eaten uncooked and foods that will be cooked before eating **MUST ALWAYS** be separated. Cross-contamination occurs when raw meats or eggs come in contact with foods that will be eaten uncooked. This is a major source of food poisoning. Always double-wrap raw meats and place them on the lowest shelf in the refrigerator so there is no way juices can drip onto fresh produce. Then use the raw meats within 1-2 days of purchase, or freeze for longer storage. Defrost frozen meats in the refrigerator, not on the counter.

When grilling or cooking raw meats or fish, make sure to place the cooked meat on a clean platter. Don't use the same platter you used to carry the food out to the grill. Wash the utensils used in grilling after the food is turned for the last time on the grill, as well as spatulas and spoons used for stir-frying or turning meat as it cooks.

Make sure to wash your hands after handling raw meats or raw eggs. Washing hands with soap and water, or using a pre-moistened antibacterial towelette is absolutely necessary after you have touched raw meat or raw eggs. Not washing hands and surfaces while cooking is a major cause of cross-contamination.

CLEAN

Wash your hands and work surfaces frequently when you are cooking. Washing with soap and warm water for at least 15 seconds, then dry with a paper towel.

CHILL

Chilling food is very important. The danger zone where bacteria multiply is between 40°F and 140°F (4°C and 6°C). Your refrigerator should be set to 40°F (4°C) or below; your freezer should be 0°F (-17°C) or below. Simple rule: serve hot foods hot, cold foods cold. Use chafing dishes or hot plates to keep food hot while serving. Use ice water baths to keep cold foods cold. Never let any food sit at room temperature for more than 2 hours - 1 hour if the ambient